

**Electric cylinders  
CASM-32/40/63**





# Electric cylinders

## CASM-32/40/63



### Features

- Modular cylinder system in three different sizes
- At least three different screws for each cylinder size
- Inline and parallel (belt) gearboxes
- Customized motor adapter plate
- Meets ISO-15552 standards
- High level of precision and repeatability
- Wide range of accessory parts

### Benefits

- Optimal for a wide range of power and lifetime requirements
- Wide range of speed and force
- Mechanically fits most applications
- Fits most of brushless DC and servo motors
- Easy to replace pneumatic cylinders
- Accurate positioning (depending upon feedback system of the motor)
- Flexibility in mounting cylinders

## Product description

CASM electric cylinders are ideally suited to perform fast and powerful linear movements. Unlike pneumatic or hydraulic cylinders, CASM electric cylinders are flexible and thus can be positioned precisely. In addition, due to a reduced number of components, the whole system is more cost effective, resulting in lower energy and maintenance costs.

The CASM modular concept enables easy connection to your preferred motor and control system. This can reduce design and programming costs considerably.

Thanks to high grade materials, a sealing system with IP54S level protection and high quality manufacturing, CASM electric cylinders can also be used long term even under adverse conditions.

The low backlash design provides positioning precision of up to  $\pm 0,01$  mm. Together with various screws for different speeds and forces, CASM electric cylinders are the optimum solution for a variety of applications.

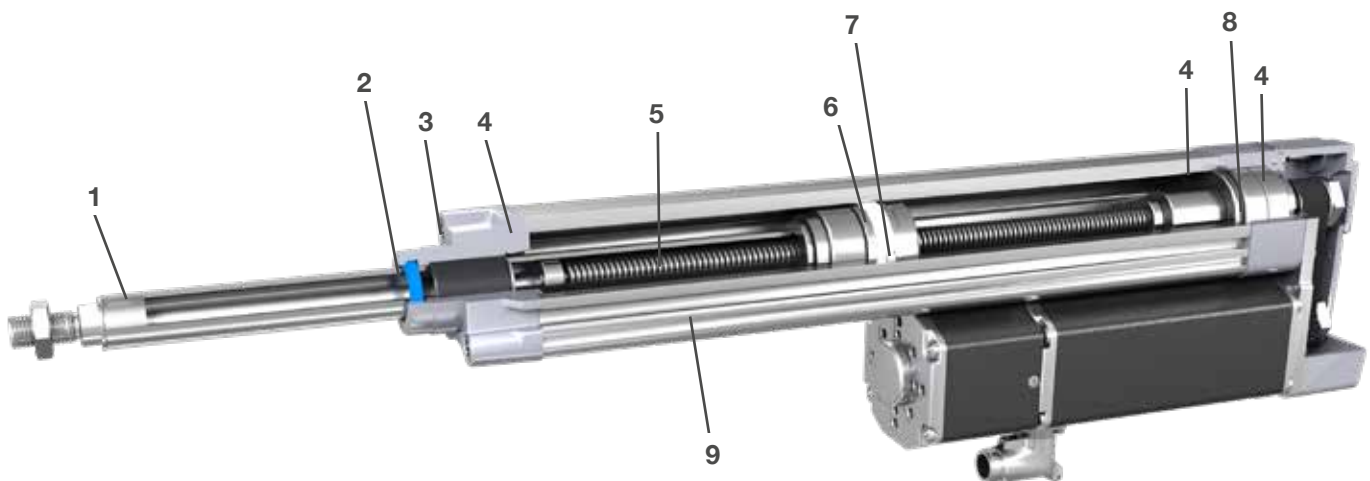

1. Stainless steel push tube
2. Shaft seal to protect against contaminants ingress
3. Sinter filter for high airflow
4. Flat seal between housings
5. High quality ball and lead screws with low axial play and low friction, lubricated for the whole product life
6. Magnet ring for proximity sensors
7. Anti-rotation device with overload protection
8. High-quality SKF bearings
9. Anodised aluminium profile with proximity sensor slots

## Performance overview of linear units

Linear unit	F <sub>max</sub> kN	F <sub>0max</sub> kN	V <sub>max</sub> mm/s
–	–	–	–
CASM-32-LS	0,3	0,7	60
CASM-32-BS	0,7	0,7	150
CASM-32-BN	0,63	0,7	500
CASM-40-LS	0,6	1,5	70
CASM-40-BS	2,375	2,375	300
CASM-40-BN	1,55	2,375	826
CASM-63-LS	1	3,7	70
CASM-63-BS	5,4	5,4	300
CASM-63-BN	5,4	5,4	533
CASM-63-BF	2,8	5,4	1 067

## Performance overview of actuators

Linear unit	Motor	Adapter	F <sub>co</sub> kN	F <sub>po</sub> kN	V <sub>max</sub> mm/s
–	–	–	–	–	–
CASM-32-LS	BG45	inline/parallel	0,300	0,300	60
CASM-32-LS	1FK7015	inline/parallel	0,300	0,300	60
CASM-32-BS	BG45	inline/parallel	0,393/0,389	0,700	150
CASM-32-BS	1FK7015	inline/parallel	0,549/0,544	0,700	150
CASM-32-BS	1FK7022	inline	0,700	0,700	150
CASM-32-BN	BG45	inline/parallel	0,132/0,131	0,497/0,492	500
CASM-32-BN	1FK7015	inline/parallel	0,185/0,183	0,528/0,523	500
CASM-32-BN	1FK7022	inline	0,449	0,630	500
CASM-40-LS	BG65S	inline/parallel	0,6/0,596	0,600	70
CASM-40-LS	1FK7022	inline/parallel	0,600	0,600	70
CASM-40-BS	BG65S	inline/parallel	0,673/0,666	1,805/1,787	298
CASM-40-BS	BG75	inline/parallel	1,239/1,227	2,375	300
CASM-40-BS	1FK7022	inline/parallel	0,908/0,899	2,375	300
CASM-40-BS	1FK7034	inline/parallel	1,709/1,692	2,375	300
CASM-40-BN	BG65S	inline/parallel	0,268/0,265	0,719/0,712	756
CASM-40-BN	BG75	inline/parallel	0,494/0,489	1,55/1,276	783
CASM-40-BN	1FK7022	inline/parallel	0,362/0,358	1,447/1,276	826
CASM-40-BN	1FK7034	inline/parallel	0,681/0,674	1,55/1,276	826
CASM-63-LS	BG75	inline/parallel	0,711/0,704	1,000	70
CASM-63-LS	1FK7034	inline/parallel	0,98/0,97	1,000	70
CASM-63-BS	BG75	inline/parallel	1,226	4,02	300
CASM-63-BS	1FK7034	inline/parallel	1,707	5,4	300
CASM-63-BS	1FK7044	inline	4,797	5,4	300
CASM-63-BN	BG75	inline/parallel	0,62/0,613	2,19/2,168	533
CASM-63-BN	1FK7034	inline/parallel	0,855/0,846	3,471/2,937	533
CASM-63-BN	1FK7044	inline	2,403	5,400	533
CASM-63-BF	BG75	inline/parallel	0,313/0,31	1,108/1,097	1 067
CASM-63-BF	1FK7034	inline/parallel	0,432/0,428	1,756/1,486	1 067
CASM-63-BF	1FK7044	inline	1,216	2,800	1 067

# Motors and gearboxes

## Servo motors

The Siemens motors provided by Ewellix come with a multi-pole resolver, a shaft-end with no keyway and a holding brake. In addition, they are equipped with a Drive-CLiQ interface. A rotating plug adapter simplifies the connection and cable routing in all installation positions. For more information, please visit the following sites:

**Motors:**

[www.siemens.com/motors](http://www.siemens.com/motors)

**Frequency converters:**

[www.siemens.com/sinamics](http://www.siemens.com/sinamics)

**Automations systems:**

[www.siemens.com/simotion](http://www.siemens.com/simotion)

**Controls:**

[www.siemens.com/simatic](http://www.siemens.com/simatic)

**Engineering software:**

[www.siemens.com/sizer](http://www.siemens.com/sizer)

**Support worldwide:**

[www.siemens.de/service](http://www.siemens.de/service)



## Motor technical data

Motor type		1FK7015-5AK71-1SH3	1FK7022-5AK71-1UH3	1FK7034-2AK71-1UH0	1FK7044-4CH71-1UH0
Designation	Unit				
Rated power (100 K)	kW	0,1	0,43	0,63	1,41
Rated speed	min <sup>-1</sup>	6 000	6 000	6 000	4 500
Rated current	A	0,85	1,4	1,3	4,9
Rated torque (100 K)	Nm	0,16	0,6	1	3
Static torque (100 K)	Nm	0,35	0,85	1,6	4
Peak torque	Nm	1	3,4	6,5	12
Inertia with brake	10 <sup>-4</sup> kgm <sup>2</sup>	0,102	0,35	0,98	1,41
Shaft diameter	mm	8	9	14	19
Weight with brake	kg	1,2	2	4	8,3

## Ordering key

Motor	CASM-32		CASM-40		CASM-63	
	Inline adapter	Parallel adapter	Inline adapter	Parallel adapter	Inline adapter	Parallel adapter
1FK7015-5AK-71-1SH3	ZBE-375530	ZBE-375540	-	-	-	-
1FK7022-5AK71-1UH3	ZBE-375537	-	ZBE-375538	ZBE-375546	-	-
1FK7034-2AK71-1UH0	-	-	ZBE-375545	ZBE-375603	ZBE-375544	ZBE-375543
1FK7044-4CH71-1UH0	-	-	-	-	ZBE-375535	-

## Brushless DC motors

Brushless DC motors are perfectly suited to replace pneumatic cylinders in many applications. The motors provided by Ewellix are equipped with internal controllers and are very simple to set up. Connected to the power supply, the motors can be programmed by a computer with up to 14 motion profiles. The profiles can be activated by 2-4 binary inputs (PLC outputs or switches).

The internal encoders enable for high positioning accuracy while the internal brake secures the system in case of a power loss.



## Motor technical data

Motor type		BG45x30PI	BG65Sx50PI	BG75x75PI
Designation	Unit			
Nominal voltage	V	24	40	40
Rated power	W	90	236	450
Rated speed	min <sup>-1</sup>	3 360	3 570	3 700
Rated current	A	4,9	7	12,7
Rated torque	Ncm	25	169	116
Peak torque	Ncm	94,2	169	410
Inertia	gcm <sup>2</sup>	44	129	652
Shaft diameter	mm	6	8	14
Weight with brake	kg	0,74	2,17	3,3

## Ordering key

Motor	CASM-32		CASM-40		CASM-63	
	Inline adapter	Parallel adapter	Inline adapter	Parallel adapter	Inline adapter	Parallel adapter
BG45x30PI	ZBE-375570	ZBE-375573	-	-	-	-
BG65Sx50PI	-	-	ZBE-375571	ZBE-375574	-	-
BG75x75PI	-	-	ZBE-375579	ZBE-375578	ZBE-375572	ZBE-375575

## Third party motors

In order to attach your preferred motor to the linear unit, Ewellix offers tailor made solutions within the specifications below.

For motor specifications which are not covered by the specifications below, please contact Ewellix.

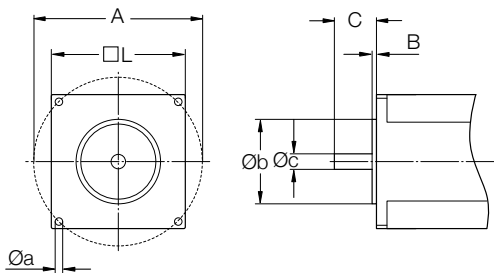

Order #	CASM-32		CASM-40			CASM-63	
	Inline adapter M/0129709	Parallel adapter M/0130493	Inline adapter M/0129710	Parallel adapter M/0130494	Parallel adapter M/0130647	Inline adapter M/0129711	Parallel adapter M/0130495
	mm	mm (in)	mm	mm (in)	mm	mm	mm
□ L	20...any value	20...47,5	40...any value	30...62	30...110	60...any value	30...86
Øb	31...75	15...32	31...75	20...44	20...65	47...95	20...65
B	1...7	1...10	1...5	1...3	1...4	1...5	1...4
ØA	36...106	19...49	36...106	24...68	24...89	52...103	24...89
Øc	6...14	6, 8, (1/4)	8...14	8, 9, (1/4), (3/8)	8, 11, 12, 13, 14	11...19	8, 11, 12, 13, 14
C	13...33	15...40	13...33	16...41	15...32	15...48	15...32



### Inline interface

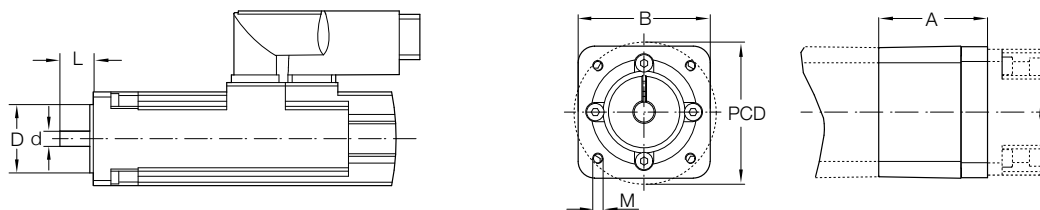

Interface	d mm	D	L	PCD	M	A mm	B	Torque max Nm	Inertia 10 <sup>-4</sup> kgm <sup>-2</sup>	Weight kg
<b>CASM-32</b>										
ZBE-375530	8	30	20	46	M4	40,9	46	2	0,006	0,25
ZBE-375537	9	40	20	64	M5	49,4	55	2	0,006	0,3
ZBE-375570	6	22	20	32	3,4	39,7	45,5	2	0,006	0,25
M/0129709	6...14	31...75	13...33	36...106	N/A	N/A	> 20	2	N/A	N/A
<b>CASM-40</b>										
ZBE-375538	9	40	20	63	M5	49,4	55	12	0,006	0,3
ZBE-375545	14	60	30	75	M6	52,4	72	12	0,006	0,3
ZBE-375571	8	32	25	45	5,5	53,5	54	12	0,006	0,3
ZBE-375579	14	32	30	45	5,3	52,4	75	12	0,006	0,3
M/0129710	8...14	31...75	13...33	36...106	N/A	N/A	> 40	12	N/A	N/A
<b>CASM-63</b>										
ZBE-375544	14	60	30	75	M6	62,4	75	25	0,200	0,35
ZBE-375535	19	80	40	100	M6	70,9	100	25	0,200	0,35
ZBE-375572	14	32	30	60	6,4	67,1	75	25	0,200	0,35
M/0129711	11...19	47...95	15...48	52...103	N/A	N/A	> 60	25	N/A	N/A

### Parallel interface

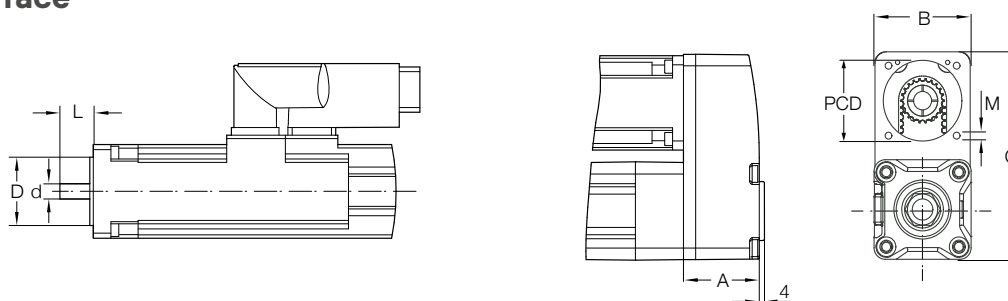

Interface	d mm (in)	D	L	PCD	M	A mm	B	C	Torque max Nm	Inertia 10 <sup>-4</sup> kgm <sup>-2</sup>	Weight kg
<b>CASM-32</b>											
ZBE-375540	8	30	20	46	M4	40,1	45,1	93,3	1	0,0016	0,35
ZBE-375573	6	22	20	32	3,4	39,5	45,1	93,3	1	0,0016	0,35
M/0130493	6, 8 (1/4")	15...32	15...40	19...49	N/A	N/A	20...47,5	93,3	1	N/A	N/A
<b>CASM-40</b>											
ZBE-375546	9	40	20	63	M5	47,1	56,6	115,3	3	0,0089	0,4
ZBE-375603	14	60	30	75	M6	58,1	74,1	157,3	3	0,0548	0,45
ZBE-375574	8	32	25	40	5,5	46,5	56,6	115,3	3	0,0089	0,4
ZBE-375578	14	32	30	45	5,3	58	74,1	156,6	3	0,0548	0,45
M/0130494	8, 9 (1/4", 3/8")	20...44	16...41	24...68	N/A	N/A	30...62	115,3	3	N/A	N/A
M/0130647	8, 11, 12, 13, 14	20...65	15...32	24...89	N/A	N/A	30...110	157,3	3	N/A	N/A
<b>CASM-63</b>											
ZBE-375543	14	60	30	75	M6	58,1	74,1	157,3	5,5	0,0548	0,45
ZBE-375575	14	32	30	60	6,4	58,1	45,1	157,3	5,5	0,0548	0,45
M/0130495	8, 11, 12, 13, 14	20...65	15...32	24...89	N/A	N/A	30...86	157,3	5,5	N/A	N/A

## Manuals

Supporting documents are available for downloading on [ewellix.com/casm](http://ewellix.com/casm) in each product page under technical data section:

- operating manual
- mounting instruction

## 3D models

Product configurators for 3D models download are available on [ewellix.com/casm](http://ewellix.com/casm), after selecting the desired actuator size.



Operating manual

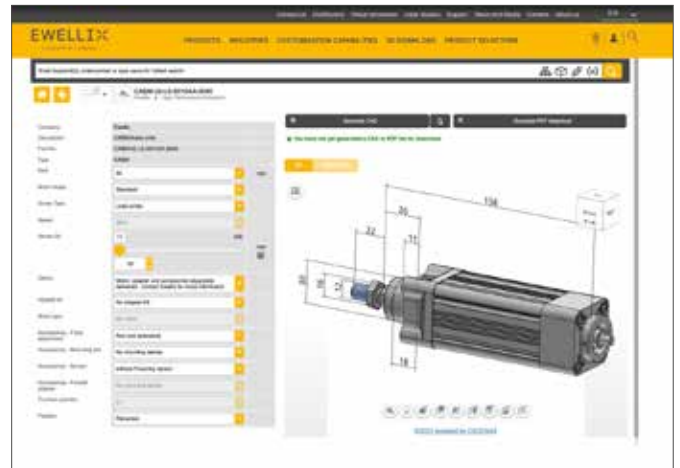

3D model configurator



# CASM-32

Linear unit



## Technical data

Designation	Symbol	Unit	CASM-32-LS	CASM-32-BS	CASM-32-BN
<b>Performance Data</b>					
Max. dynamic axial force	$F_{max}$	kN	0,3	0,7	0,63
Max. static axial force	$F_{0max}$	kN	0,7	0,7	0,7
Dynamic load capacity	C	kN	N/A	2,8	2,5
Maximum torque to reach $F_{max}$	$M_{max}$	Nm	0,24	0,45	1,19
Max. linear speed	$v_{max}$	mm/s	60	150	500
Max. rotational speed	$n_{max}$	1/min	2 400	3 000	3 000
Max. acceleration	$a_{max}$	m/s <sup>2</sup>	1	6	6
Duty cycle	$D_{unit}$	%	60	100	100
<b>Mechanical Data</b>					
Screw type	–	–	Lead screw	Ball screw	Ball screw
Screw diameter	$d_{screw}$	mm	9	10	10
Screw lead	$p_{screw}$	mm	1,5	3	10
Lead accuracy	–	–	N/A	G7	G7
Stroke	s	mm	50...400	50...400	50...400
Internal overstroke each side	$s_0$	mm	1	1	1
Backlash	$s_{backlash}$	mm	N/A	0,06	0,06
Efficiency	$\eta_{lu}$	%	30	75	84
Inertia @ 0 mm stroke	$J_{lu}$	10 <sup>-4</sup> kgm <sup>2</sup>	0,0413	0,0420	0,0420
Δ Inertia per 100 mm stroke	ΔJ	10 <sup>-4</sup> kgm <sup>2</sup>	0,0036	0,0047	0,0047
Weight @ 0 mm stroke	$m_{lu}$	kg	0,74	0,74	0,74
Δ weight per 100 mm stroke	Δm	kg	0,34	0,34	0,34
<b>Environment and Standards</b>					
Ambient temperature	$T_{ambient}$	°C	0...+50	0...+50	0...+50
Max. humidity	φ	%	95	95	95
Degree of protection <sup>1)</sup>	IP	–	54S	54S	54S
Standard	–	–	ISO 15552	ISO 15552	ISO 15552

<sup>1)</sup> IP65S protection on request. Please contact Ewellix.

### Dimensional drawing

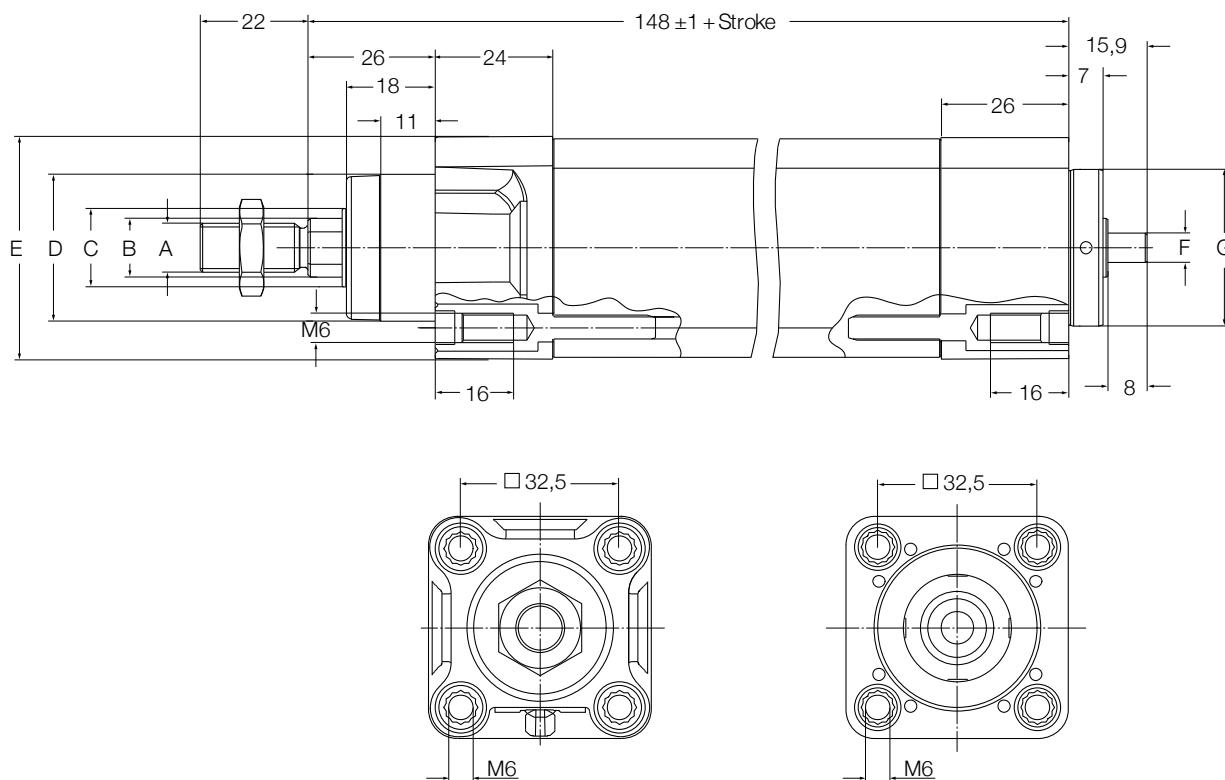

	A	B	C	D	E	F	G
	mm						
CASM-32	M10 × 1,25	Ø12	Ø16	Ø30d11	□ 45,7	Ø6h6	Ø32 <sup>-0,05</sup> / <sub>-0,07</sub>

### Performance diagrams

Axial force [N]

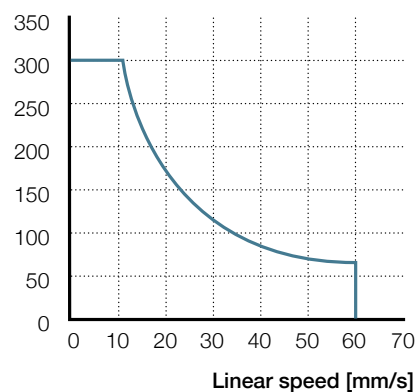

Radial load [N]

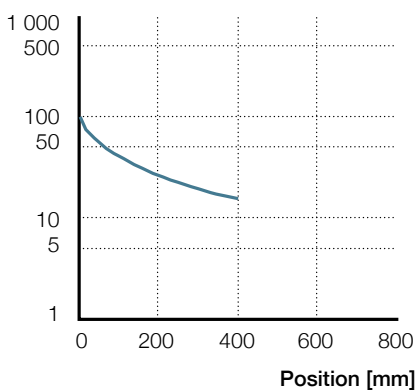

F<sub>m</sub> [N]

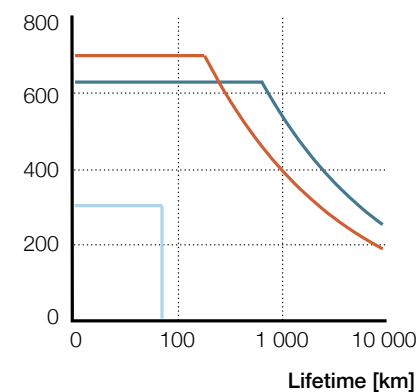

Valid only for CASM-32-LS.  
No limitation for ball screw types  
(max. load at max. speed).

The radial load acts perpendicular to  
the moving direction.

CASM-32-BN

CASM-32-BS

CASM-32-LS

### Ordering key

See page 18

# CASM-40

Linear unit



## Technical data

Designation	Symbol	Unit	CASM-40-LS	CASM-40-BS	CASM-40-BN
<b>Performance Data</b>					
Max. dynamic axial force	$F_{max}$	kN	0,6	2,375	1,55
Max. static axial force	$F_{0max}$	kN	1,5	2,375	2,375
Dynamic load capacity	C	kN	N/A	4,8	6
Maximum torque to reach $F_{max}$	$M_{max}$	Nm	0,63	2,22	3,64
Max. linear speed	$v_{max}$	mm/s	70	300	826
Max. rotational speed	$n_{max}$	1/min	1 680	3 600	3 900
Max. acceleration	$a_{max}$	m/s <sup>2</sup>	1	6	6
Duty cycle	$D_{unit}$	%	60	100	100
<b>Mechanical Data</b>					
Screw type	–	–	Lead screw	Ball screw	Ball screw
Screw diameter	$d_{screw}$	mm	12,5	12	12,7
Screw lead	$p_{screw}$	mm	2,5	5	12,7
Lead accuracy	–	–	N/A	G7	G7
Stroke	s	mm	100...600	100...600	100...600
Internal overstroke each side	$s_0$	mm	1	1	1
Backlash	$s_{backlash}$	mm	N/A	0,07	0,07
Efficiency	$\eta_{lu}$	%	38	85	86
Inertia @ 0 mm stroke	$J_{lu}$	10 <sup>-4</sup> kgm <sup>2</sup>	0,1262	0,1246	0,1279
$\Delta$ Inertia per 100 mm stroke	$\Delta J$	10 <sup>-4</sup> kgm <sup>2</sup>	0,0123	0,0103	0,0144
Weight @ 0 mm stroke	$m_{lu}$	kg	1,25	1,26	1,29
$\Delta$ weight per 100 mm stroke	$\Delta m$	kg	0,46	0,46	0,46
<b>Environment and Standards</b>					
Ambient temperature	$T_{ambient}$	°C	0...+50	0...+50	0...+50
Max. humidity	$\phi$	%	95	95	95
Degree of protection <sup>1)</sup>	IP	–	54S	54S	54S
Standards	–	–	ISO 15552	ISO 15552	ISO 15552

<sup>1)</sup> IP65S protection on request. Please contact Ewellix.

### Dimensional drawing

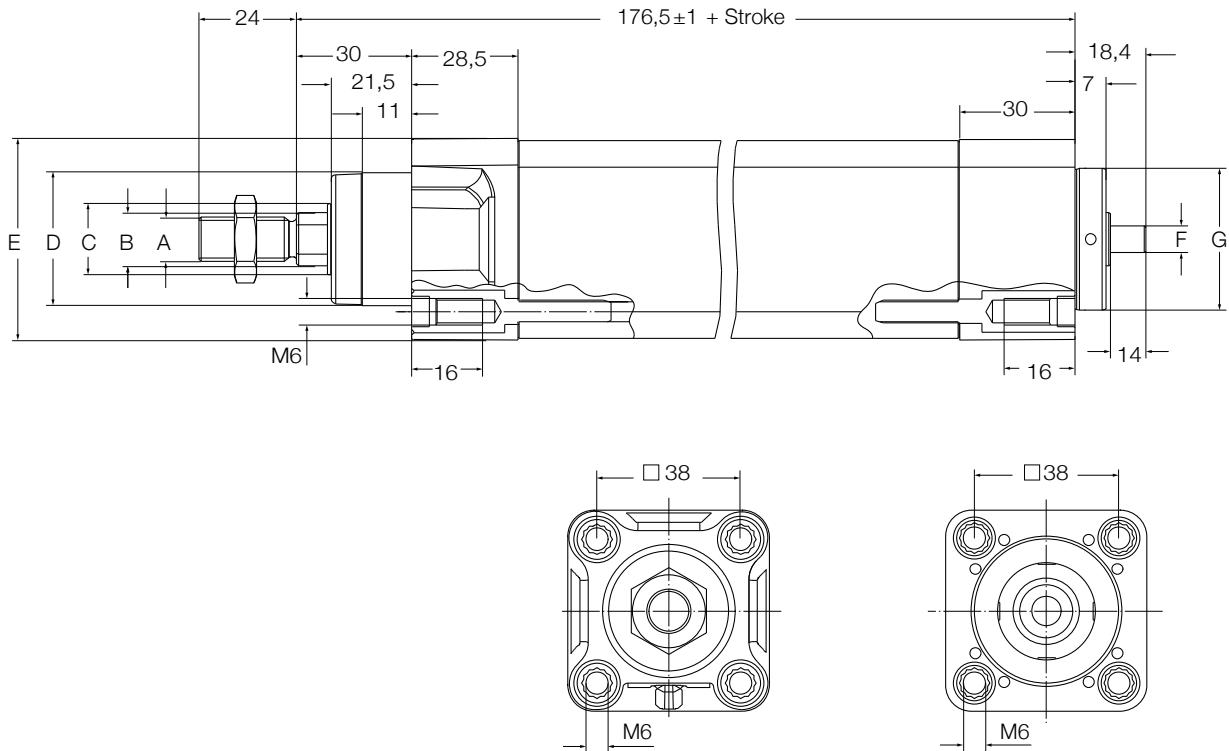

	A	B	C	D	E	F	G
	mm						
CASM-40	M12 x 1,25	$\varnothing 16$	$\varnothing 20$	$\varnothing 35d11$	$\square 54,3$	$\varnothing 8h6$	$\varnothing 40$ $\begin{matrix} -0,08 \\ -0,1 \end{matrix}$

### Performance diagrams

Axial force [N]

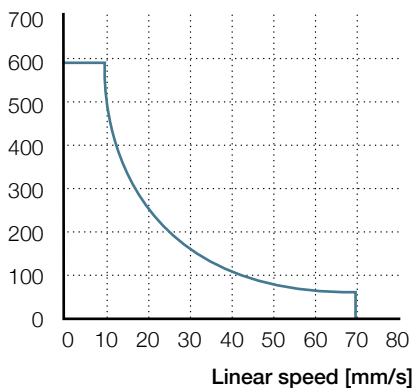

Radial load [N]

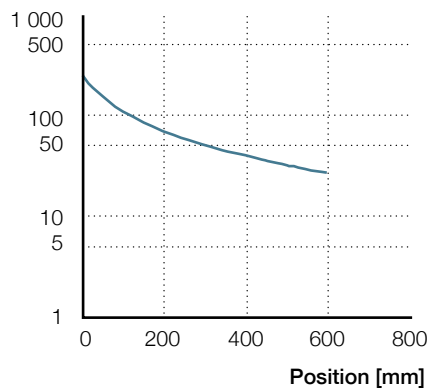

$F_m$  [N]

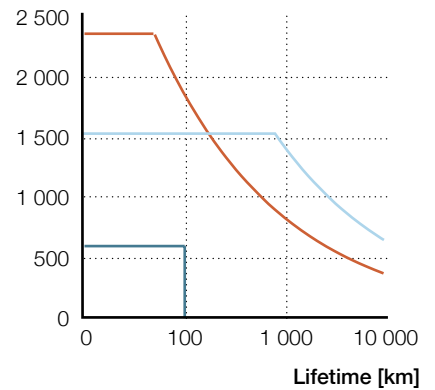

Valid only for CASM-40-LS.  
No limitation for ball screw types  
(max. load at max. speed).

The radial load acts perpendicular  
to the moving direction.

CASM-40-LS    CASM-40-BS

CASM-40-BN

### Ordering key

See page 18

# CASM-63

Linear unit



## Technical data

Designation	Symbol	Unit	CASM-63-LS	CASM-63-BS	CASM-63-BN	CASM-63-BF
<b>Performance Data</b>						
Max. dynamic axial force	$F_{max}$	kN	1	5,4	5,4	2,8
Max. static axial force	$F_{0max}$	kN	3,7	5,4	5,4	5,4
Dynamic load capacity	C	kN	N/A	13,7	21	10
Maximum torque to reach $F_{max}$	$M_{max}$	Nm	1,63	5,06	10,11	10,36
Max. linear speed	$v_{max}$	mm/s	70	300	533	1 067
Max. rotational speed	$n_{max}$	1/min	1 050	3600	3 200	3 200
Max. acceleration	$a_{max}$	m/s <sup>2</sup>	1	5	6	6
Duty cycle	$D_{unit}$	%	60	100	100	100
<b>Mechanical Data</b>						
Screw type	–	–	Lead screw	Ball screw	Ball screw	Ball screw
Screw diameter	$d_{screw}$	mm	20	20	20	20
Screw lead	$p_{screw}$	mm	4	5	10	20
Lead accuracy	–	–	N/A	G7	G7	G7
Stroke	s	mm	100...800	100...800	100...800	100...800
Internal overstroke each side	$s_0$	mm	1	1	1	1
Backlash	$s_{backlash}$	mm	N/A	0,07	0,07	0,07
Efficiency	$\eta_{lu}$	%	39	85	85	86
Inertia @ 0 mm stroke	$J_{lu}$	10 <sup>-4</sup> kgm <sup>2</sup>	0,76	0,76	0,7600	0,7636
$\Delta$ Inertia per 100 mm stroke	$\Delta J$	10 <sup>-4</sup> kgm <sup>2</sup>	0,0809	0,12	0,0809	0,0855
Weight @ 0 mm stroke	$m_{lu}$	kg	2,80	2,9	2,90	2,90
$\Delta$ weight per 100 mm stroke	$\Delta m$	kg	0,81	0,81	0,81	0,81
<b>Environment and Standards</b>						
Ambient temperature	$T_{ambient}$	°C	0...+50	0...+50	0...+50	0...+50
Max. humidity	$\phi$	%	95	95	95	95
Degree of protection <sup>1)</sup>	IP	–	54S	54S	54S	54S
Standards	–	–	ISO 15552	ISO 15552	ISO 15552	ISO 15552

<sup>1)</sup> IP65S protection on request. Please contact Ewellix.



### Dimensional drawing

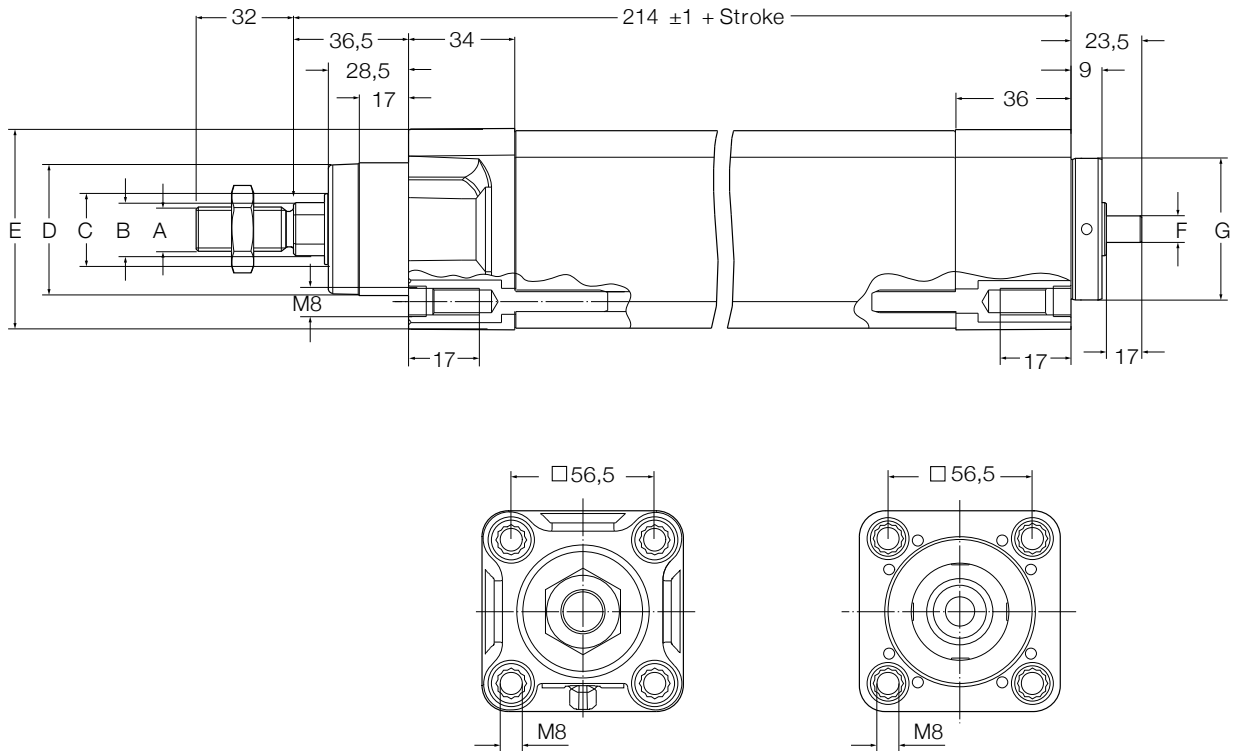

	A	B	C	D	E	F	G
		mm					
CASM-63	M16 × 1,5	Ø20	Ø28	Ø45d11	□ 75	Ø12h6	Ø60 <sup>-0.05</sup> / <sub>-0.08</sub>

### Performance diagrams

Axial force [N]

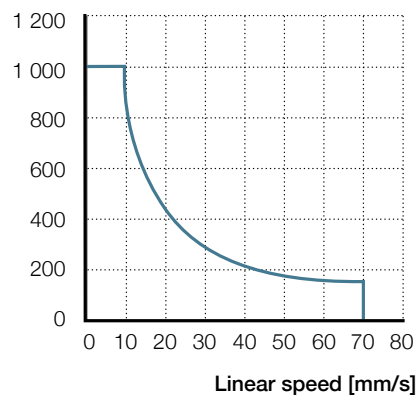

Radial load [N]

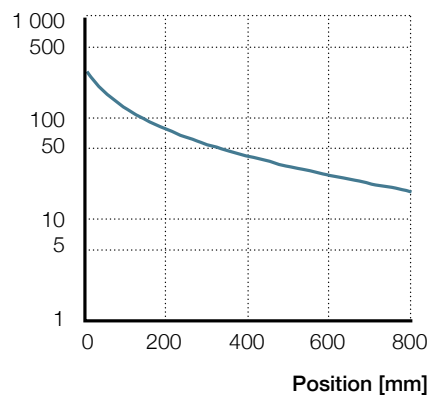

F<sub>m</sub> [N]

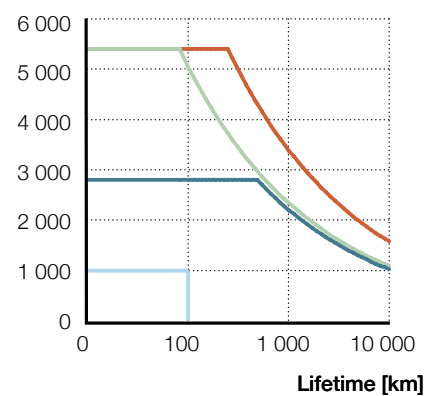

Valid only for CASM-63-LS.  
No limitation for ball screw types  
(max. load at max. speed).

The radial load acts  
perpendicular to the moving  
direction.

**CASM-63-BF**

**CASM-63-BN**

**CASM-63-LS**

**CASM-63-BS**

### Ordering key

See page 18

## Ordering key

### Linear units

C A S M - 3 2 - B S - 0 3 0 0 A M - 0 0 0

**Screw**

- LS Lead screw 9 × 1,5 mm
- BS Ball screw 10 × 3 mm
- BN Ball screw 10 × 10 mm

**Stroke**

- 50 mm
- 100 mm
- 150 mm
- 200 mm
- 300 mm
- 400 mm

**Option<sup>1)</sup>**

- A Motor, adapter and accessories separately delivered
- M Motor, adapter and foot mountings<sup>2)</sup> pre-mounted

**Customer option**

- 000 No option

C A S M - 4 0 - L S - 0 1 0 0 A A - 0 0 0

**Screw**

- LS Lead screw 12,5 × 2,5 mm
- BS Ball screw 12 × 5 mm
- BN Ball screw 12,7 × 12,7 mm

**Stroke**

- 100 mm
- 200 mm
- 300 mm
- 400 mm
- 500 mm
- 600 mm

**Option<sup>1)</sup>**

- A Motor, adapter and accessories separately delivered
- M Motor, adapter and foot mountings<sup>2)</sup> pre-mounted

**Customer option**

- 000 No option

C A S M - 6 3 - B F - 0 7 0 0 A A - 0 0 0

**Screw**

- LS Lead screw 20 × 4 mm
- BS Ball screw 20 × 5 mm
- BN Ball screw 20 × 10 mm
- BF Ball screw 20 × 20 mm

**Stroke**

- 100 mm
- 200 mm
- 300 mm
- 400 mm
- 500 mm
- 600 mm
- 700 mm
- 800 mm

**Option<sup>1)</sup>**

- A Motor, adapter and accessories separately delivered
- M Motor, adapter and foot mountings<sup>2)</sup> pre-mounted

**Customer option**

- 000 No option

<sup>1)</sup> Motor, adapter kit and accessories need to be ordered separately

<sup>2)</sup> Foot mountings pre-mounted on inline version only

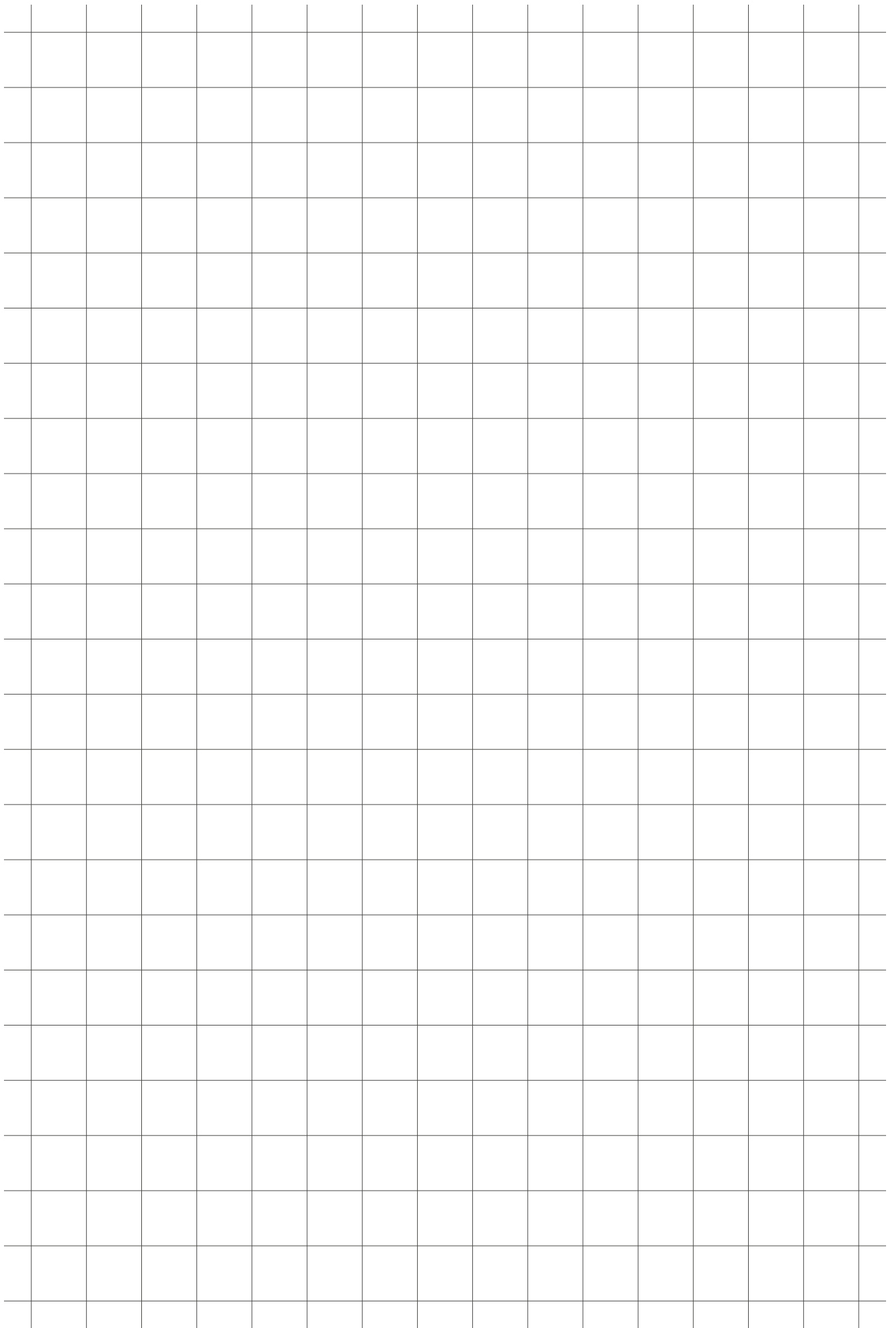

# CASM-32-LS

Electric cylinder motor,  
inline configuration



## Technical data

Designation	Symbol	Unit	BLDC motor BG45	Servo motor 1FK7015
<b>Performance Data</b>				
Continuous force @ zero speed	$F_{c0}$	kN	0,300	0,300
Continuous force @ max. speed	$F_c$	kN	0,047	0,047
Peak force @ zero speed	$F_{p0}$	kN	0,300	0,300
Peak force @ max. speed	$F_p$	kN	0,300	0,300
Dynamic load capacity	C	kN	N/A	N/A
Holding force (motorbrake option)	$F_{Hold}$	kN	0,700	0,700
Max. linear speed	$v_{max}$	mm/s	60	60
Max. acceleration	$a_{max}$	m/s <sup>2</sup>	1	1
Duty cycle	D	%	60	60
<b>Mechanical Data</b>				
Screw type	–	–	Lead screw	Lead screw
Screw diameter	$d_{screw}$	mm	9	9
Screw lead	$p_{screw}$	mm	1,5	1,5
Lead accuracy	–	–	N/A	N/A
Stroke	s	mm	50...400	50...400
Internal overstroke each side	$s_0$	mm	1	1
Backlash	$s_{backlash}$	mm	N/A	N/A
Gear reduction	i	–	1	1
Efficiency	$\eta$	%	23	20
Inertia @ 0 mm stroke	J	10 <sup>-4</sup> kgm <sup>2</sup>	0,0913	0,1303
Δ Inertia per 100 mm stroke	ΔJ	10 <sup>-4</sup> kgm <sup>2</sup>	0,0036	0,0036
Inertia of optional brake	$J_{brake}$	10 <sup>-4</sup> kgm <sup>2</sup>	0,0000	0,0190
Weight @ 0 mm stroke	m	kg	1,61	2,09
Δ weight per 100 mm stroke	Δm	kg	0,34	0,34
Weight of optional brake	$m_{brake}$	kg	0,12	0,10
<b>Electrical Data</b>				
Motor type	–	–	Brushless DC	Servo
Nominal voltage	U	V DC	24	N/A
Nominal current	I	A	4,9	1,0
Peak current	$I_{peak}$	A	15,0	1,6
Nominal power	P	kW	0,091	0,100
<b>Environment and Standards</b>				
Ambient temperature	$T_{ambient}$	°C	0...+50	0...+50
Degree of protection	IP	–	54S	54S
Standards	–	–	ISO 15552	ISO 15552

## Ordering information

	BG45	1FK7015
Linear unit	see <b>page 12</b>	see <b>page 12</b>
Motor	BG45X30PI	1FZ7015-5AK71-1SH3
Adapter	ZBE-375570	ZBE-375530

For more information regarding motors and motor adapters, please visit **page 5**

### Dimensional drawing

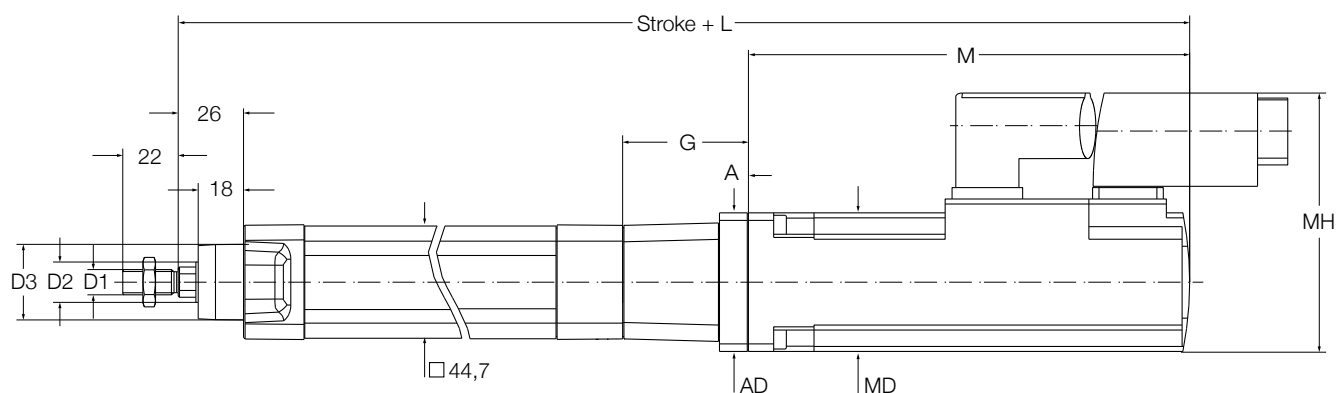

Motor	D1	D2 mm	D3	L	G	A	AD	M	MD	MH
BG45	M10 × 1,25	Ø16	Ø30	347,7	39,7	6,7	4,5	160	44	60,8
1FK7015	M10 × 1,25	Ø16	Ø30	353,9	40,9	9	40	165	40	86

### Performance diagrams

Axial force [N]

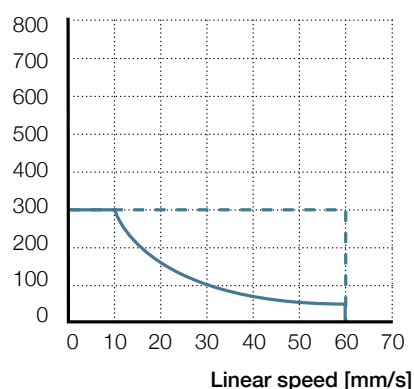

Radial load [N]

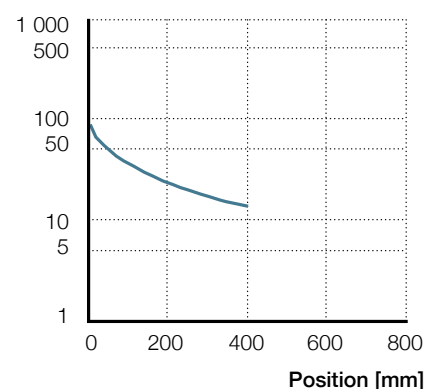

$F_m$  [N]

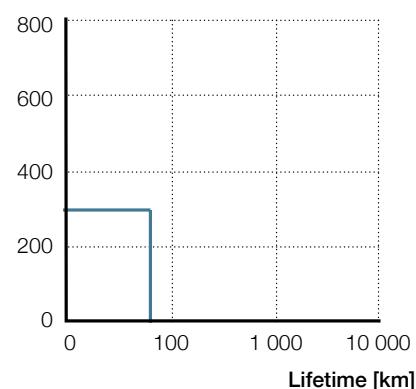

BG45 – 1FK7015

—  $F_{cont}$     - - -  $F_{peak}$

— CASM-32-LS

— CASM-32-LS

### Ordering key

See page 60

# CASM-32-LS

Electric cylinder motor,  
parallel configuration



## Technical data

Designation	Symbol	Unit	BLDC motor BG45	Servo motor 1FK7015
<b>Performance Data</b>				
Continuous force @ zero speed	$F_{c0}$	kN	0,300	0,300
Continuous force @ max. speed	$F_c$	kN	0,047	0,047
Peak force @ zero speed	$F_{p0}$	kN	0,300	0,300
Peak force @ max. speed	$F_p$	kN	0,300	0,300
Dynamic load capacity	C	kN	N/A	N/A
Holding force (motorbrake option)	$F_{Hold}$	kN	0,700	0,700
Max. linear speed	$v_{max}$	mm/s	60	60
Max. acceleration	$a_{max}$	m/s <sup>2</sup>	1	1
Duty cycle	D	%	60	60
<b>Mechanical Data</b>				
Screw type	–	–	Lead screw	Lead screw
Screw diameter	$d_{screw}$	mm	9	9
Screw lead	$p_{screw}$	mm	1,5	1,5
Lead accuracy	–	–	N/A	N/A
Stroke	s	mm	50...400	50...400
Internal overstroke each side	$s_0$	mm	1	1
Backlash	$s_{backlash}$	mm	N/A	N/A
Gear reduction	i	–	1	1
Efficiency	$\eta$	%	23	20
Inertia @ 0 mm stroke	J	10 <sup>-4</sup> kgm <sup>2</sup>	0,0869	0,1259
$\Delta$ Inertia per 100 mm stroke	$\Delta J$	10 <sup>-4</sup> kgm <sup>2</sup>	0,0036	0,0036
Inertia of optional brake	$J_{brake}$	10 <sup>-4</sup> kgm <sup>2</sup>	0,0000	0,0190
Weight @ 0 mm stroke	m	kg	1,71	2,19
$\Delta$ weight per 100 mm stroke	$\Delta m$	kg	0,34	0,34
Weight of optional brake	$m_{brake}$	kg	0,12	0,10
<b>Electrical Data</b>				
Motor type	–	–	Brushless DC	Servo
Nominal voltage	U	V DC	24	n/a
Nominal current	I	A	4,9	1,0
Peak current	$I_{peak}$	A	15,0	1,6
Nominal power	P	kW	0,091	0,100
<b>Environment and Standards</b>				
Ambient temperature	$T_{ambient}$	°C	0...+50	0...+50
Degree of protection	IP	–	54S	54S
Standards	–	–	ISO 15552	ISO 15552

## Ordering information

	BG45	1FK7015
Linear unit	see <b>page 12</b>	see <b>page 12</b>
Motor	BG45X30PI	1FZ7015-5AK71-1SH3
Adapter	ZBE-375573	ZBE-375540

For more information regarding motors and motor adapters, please visit **page 5**

### Dimensional drawing

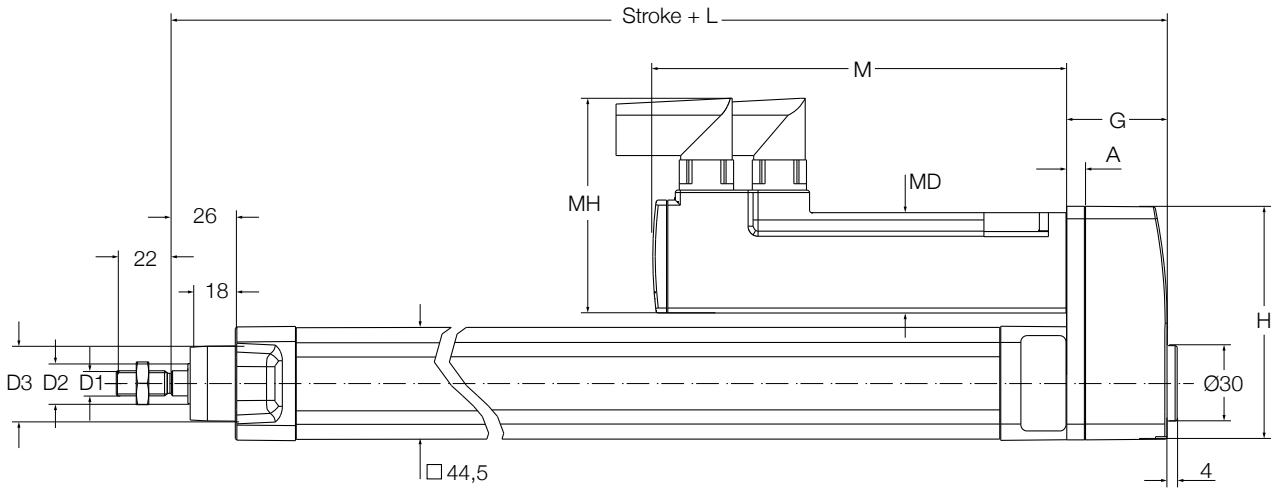

Motor	D1	D2	D3	L	G	A	H	M	MD	MH
BG45	M10 × 1,25	Ø16	Ø30	187,5	39,5	7	93,3	160	44	60,8
1FK7015	M10 × 1,25	Ø16	Ø30	188,1	40,1	7	93,3	165	40	86

### Performance diagrams

Axial force [N]

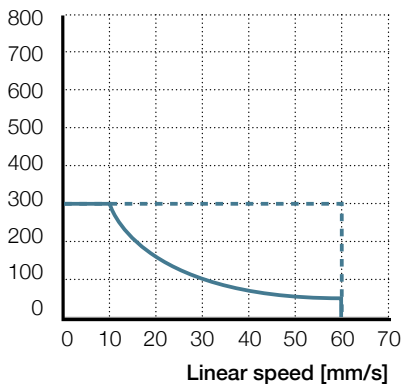

BG45 – 1FK7015

— F<sub>cont</sub>    - - - F<sub>peak</sub>

Radial load [N]

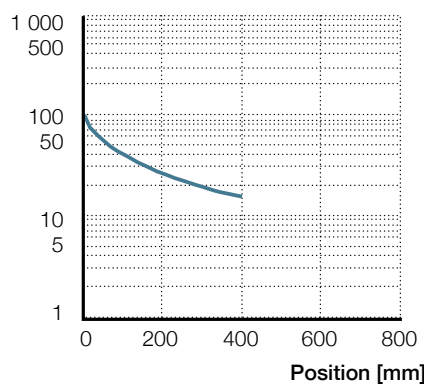

— CASM-32-LS

F<sub>m</sub> [N]

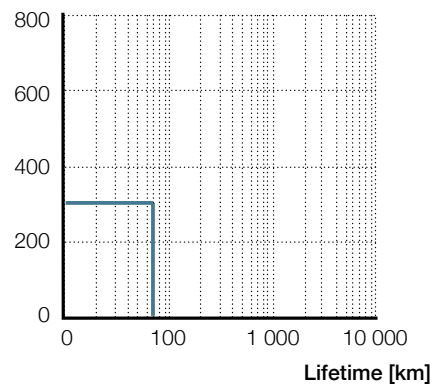

— CASM-32-LS

### Ordering key

See page 60

# CASM-32-BS

Electric cylinder motor,  
inline configuration



## Technical data

Designation	Symbol	Unit	BLDC motor BG45	Servo motor 1FK7015	Servo motor 1FK7022
<b>Performance Data</b>					
Continuous force @ zero speed	$F_{c0}$	kN	0,393	0,550	0,700
Continuous force @ max. speed	$F_c$	kN	0,393	0,503	0,700
Peak force @ zero speed	$F_{p0}$	kN	0,700	0,700	0,700
Peak force @ max. speed	$F_p$	kN	0,603	0,700	0,700
Dynamic load capacity	C	kN	2,8	2,8	2,8
Holding force (motorbrake option)	$F_{Hold}$	kN	0,558	0,700	0,279
Max. linear speed	$v_{max}$	mm/s	150	150	150
Max. acceleration	$a_{max}$	m/s <sup>2</sup>	6	6	6
Duty cycle	D	%	100	100	100
<b>Mechanical Data</b>					
Screw type	–	–	Ball screw	Ball screw	Ball screw
Screw diameter	$d_{screw}$	mm	10	10	10
Screw lead	$p_{screw}$	mm	3	3	3
Lead accuracy	–	–	G7	G7	G7
Stroke	s	mm	50...400	50...400	50...400
Internal overstroke each side	$s_0$	mm	1	1	1
Backlash	$s_{backlash}$	mm	0,06	0,06	0,06
Gear reduction	i	–	1	1	1
Efficiency	$\eta$	%	58	51	65
Inertia @ 0 mm stroke	J	10 <sup>-4</sup> kgm <sup>2</sup>	0,0920	0,1310	0,3280
$\Delta$ Inertia per 100 mm stroke	$\Delta J$	10 <sup>-4</sup> kgm <sup>2</sup>	0,0047	0,0047	0,0047
Inertia of optional brake	$J_{brake}$	10 <sup>-4</sup> kgm <sup>2</sup>	0	0,0190	0,0700
Weight @ 0 mm stroke	m	kg	1,61	2,09	2,84
$\Delta$ weight per 100 mm stroke	$\Delta m$	kg	0,34	0,34	0,34
Weight of optional brake	$m_{brake}$	kg	0,12	0,10	0,20
<b>Electrical Data</b>					
Motor type	–	–	Brushless DC	Servo	Servo
Nominal voltage	U	V DC	24	N/A	N/A
Nominal current	I	A	4,9	1,0	1,4
Peak current	$I_{peak}$	A	15,0	1,6	1,8
Nominal power	P	kW	0,091	0,100	0,400
<b>Environment and Standards</b>					
Ambient temperature	$T_{ambient}$	°C	0...+50	0...+50	0...+50
Degree of protection	IP	–	54S	54S	54S
Standards	–	–	ISO 15552	ISO 15552	ISO 15552

## Ordering information

	BG45	1FK7015	1FK7022
Linear unit	see <a href="#">page 12</a>	see <a href="#">page 12</a>	see <a href="#">page 12</a>
Motor	BG45X30PI	1FZ7015-5AK71-1SH3	1FK7022-5AK71-1UH3
Adapter	ZBE-375570	ZBE-375530	ZBE-375537

For more information regarding motors and motor adapters, please visit [page 5](#)



### Dimensional drawing

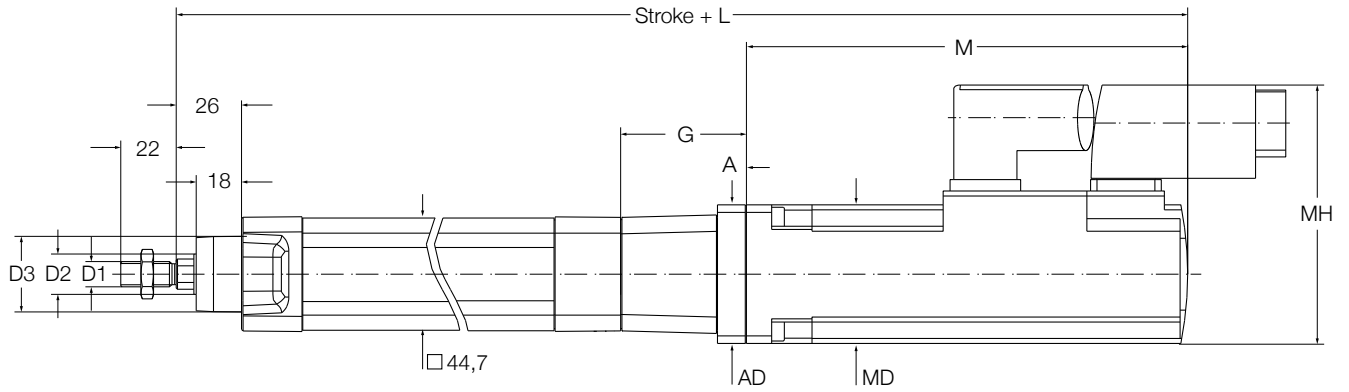

Motor	D1	D2 mm	D3	L	G	A	AD	M	MD	MH
BG45	M10 × 1,25	Ø16	Ø30	347,7	39,7	6,7	45,5	160	44	60,8
1FK7015	M10 × 1,25	Ø16	Ø30	353,9	40,9	9	40	165	40	86
1FK7022	M10 × 1,25	Ø16	Ø30	372,4	49,4	11	55	175	55	103

### Performance diagrams

Axial force [N]

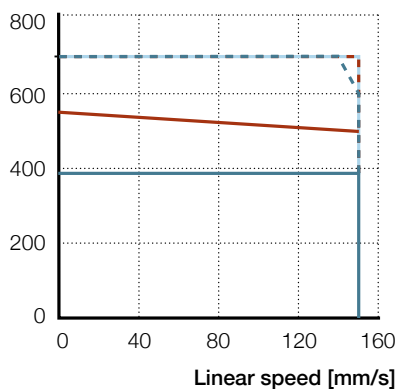

Radial load [N]

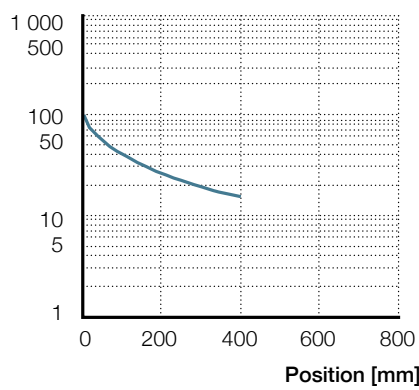

F<sub>m</sub> [N]

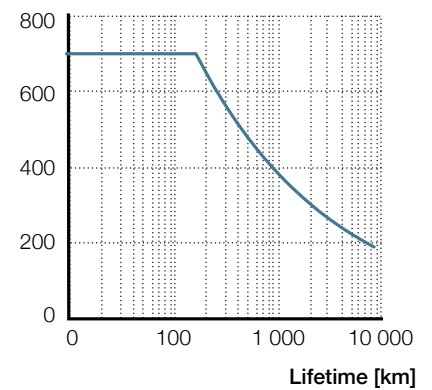

<b>BG45</b>	<b>1FK7015</b>	<b>1FK7022</b>
— F <sub>cont</sub>	— F <sub>cont</sub>	— F <sub>cont</sub>
- - - F <sub>peak</sub>	- - - F <sub>peak</sub>	- - - F <sub>peak</sub>

— CASM-32-BS

— CASM-32-BS

### Ordering key

See page 60

# CASM-32-BS

Electric cylinder motor,  
parallel configuration



## Technical data

Designation	Symbol	Unit	BLDC motor BG45	Servo motor 1FK7015
<b>Performance Data</b>				
Continuous force @ zero speed	$F_{c0}$	kN	0,389	0,544
Continuous force @ max. speed	$F_c$	kN	0,389	0,498
Peak force @ zero speed	$F_{p0}$	kN	0,700	0,700
Peak force @ max. speed	$F_p$	kN	0,597	0,700
Dynamic load capacity	C	kN	2,8	2,8
Holding force (motorbrake option)	$F_{Hold}$	kN	0,558	0,700
Max. linear speed	$v_{max}$	mm/s	150	150
Max. acceleration	$a_{max}$	m/s <sup>2</sup>	6	6
Duty cycle	D	%	100	100
<b>Mechanical Data</b>				
Screw type	–	–	Ball screw	Ball screw
Screw diameter	$d_{screw}$	mm	10	10
Screw lead	$p_{screw}$	mm	3	3
Lead accuracy	–	–	G7	G7
Stroke	s	mm	50...400	50...400
Internal overstroke each side	$s_0$	mm	1	1
Backlash	$s_{backlash}$	mm	0,06	0,06
Gear reduction	i	–	1	1
Efficiency	$\eta$	%	57	50
Inertia @ 0 mm stroke	J	10 <sup>-4</sup> kgm <sup>2</sup>	0,0875	0,1265
$\Delta$ Inertia per 100 mm stroke	$\Delta J$	10 <sup>-4</sup> kgm <sup>2</sup>	0,0047	0,0047
Inertia of optional brake	$J_{brake}$	10 <sup>-4</sup> kgm <sup>2</sup>	0,0000	0,019
Weight @ 0 mm stroke	m	kg	1,71	2,19
$\Delta$ weight per 100 mm stroke	$\Delta m$	kg	0,34	0,34
Weight of optional brake	$m_{brake}$	kg	0,12	0,1
<b>Electrical Data</b>				
Motor type	–	–	Brushless DC	Servo
Nominal voltage	U	V DC	24	N/A
Nominal current	I	A	4,9	1
Peak current	$I_{peak}$	A	15,0	1,6
Nominal power	P	kW	0,091	0,1
<b>Environment and Standards</b>				
Ambient temperature	$T_{ambient}$	°C	0...+50	0...+50
Degree of protection	IP	–	54S	54S
Standards	–	–	ISO 15552	ISO 15552

## Ordering information

	BG45	1FK7015
Linear unit	see <b>page 12</b>	see <b>page 12</b>
Motor	BG45X30PI	1FZ7015-5AK71-1SH3
Adapter	ZBE-375573	ZBE-375540

For more information regarding motors and motor adapters, please visit **page 5**

### Dimensional drawing

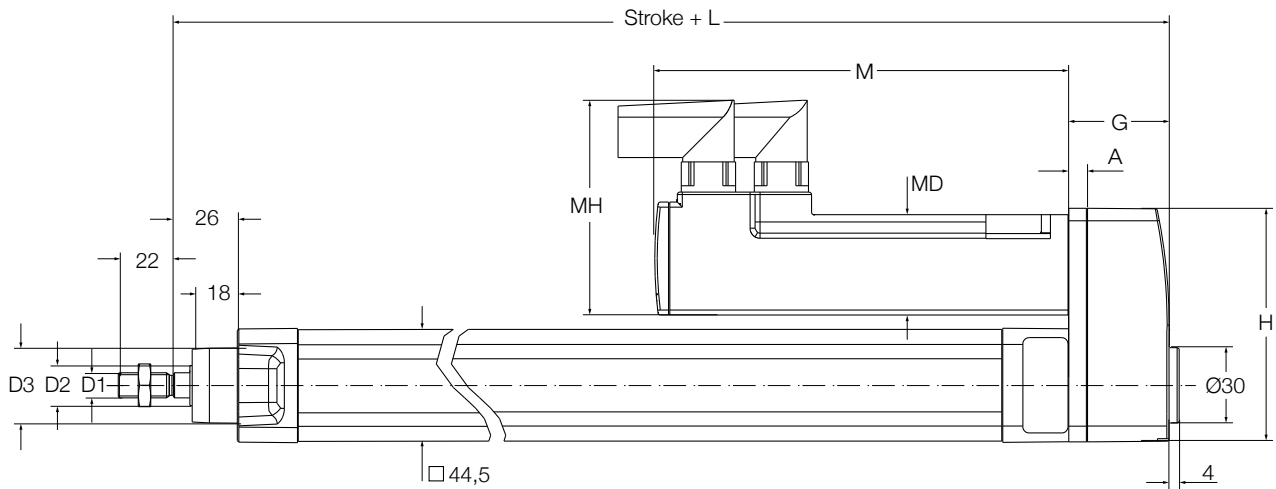

Motor	D1	D2	D3	L	G	A	H	M	MD	MH
BG45	M10 × 1,25	Ø16	Ø30	187,5	39,5	7	93,3	160	44	60,8
1FK7015	M10 × 1,25	Ø16	Ø30	188,1	40,1	7	93,3	165	40	86

### Performance diagrams

Axial force [N]

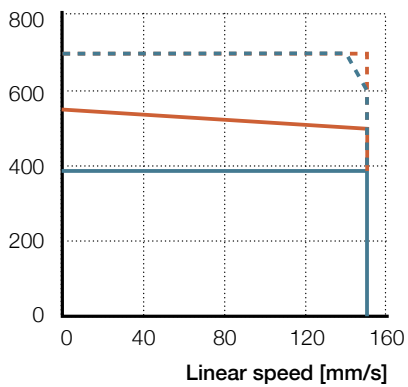

BG45      1FK7015  
 — F<sub>cont</sub>    - - F<sub>peak</sub>    — F<sub>cont</sub>    - - F<sub>peak</sub>

Radial load [N]

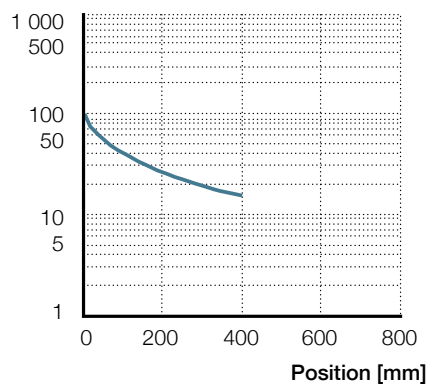

— CASM-32-BS

F<sub>m</sub> [N]

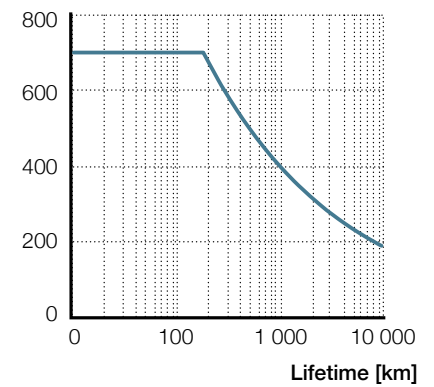

— CASM-32-BS

### Ordering key

See page 60

# CASM-32-BN

Electric cylinder motor,  
inline configuration



## Technical data

Designation	Symbol	Unit	BLDC motor BG45	Servo motor 1FK7015	Servo motor 1FK7022
<b>Performance Data</b>					
Continuous force @ zero speed	$F_{c0}$	kN	0,132	0,185	0,449
Continuous force @ max. speed	$F_c$	kN	0,132	0,169	0,385
Peak force @ zero speed	$F_{p0}$	kN	0,497	0,528	0,630
Peak force @ max. speed	$F_p$	kN	0,203	0,528	0,630
Dynamic load capacity	C	kN	2,5	2,5	2,5
Holding force (motorbrake option)	$F_{Hold}$	kN	0,131	0,151	0,357
Max. linear speed	$v_{max}$	mm/s	500	500	500
Max. acceleration	$a_{max}$	m/s <sup>2</sup>	6	6	6
Duty cycle	D	%	100	100	100
<b>Mechanical Data</b>					
Screw type	–	–	Ball screw	Ball screw	Ball screw
Screw diameter	$d_{screw}$	mm	10	10	10
Screw lead	$p_{screw}$	mm	10	10	10
Lead accuracy	–	–	G7	G7	G7
Stroke	s	mm	50...400	50...400	50...400
Internal overstroke each side	$s_0$	mm	1	1	1
Backlash	$s_{backlash}$	mm	0,06	0,06	0,06
Gear reduction	i	–	1	1	1
Efficiency	–	%	65	57	72
Inertia @ 0 mm stroke	J	10 <sup>-4</sup> kgm <sup>2</sup>	0,0920	0,1310	0,3280
Δ Inertia per 100 mm stroke	ΔJ	10 <sup>-4</sup> kgm <sup>2</sup>	0,0047	0,0047	0,0047
Inertia of optional brake	$J_{brake}$	10 <sup>-4</sup> kgm <sup>2</sup>	0,0000	0,0190	0,0700
Weight @ 0 mm stroke	m	kg	1,61	2,09	2,84
Δ weight per 100 mm stroke	Δm	kg	0,34	0,34	0,34
Weight of optional brake	$m_{brake}$	kg	0,12	0,10	0,20
<b>Electrical Data</b>					
Motor type	–	–	Brushless DC	Servo	Servo
Nominal voltage	U	V DC	24	N/A	N/A
Nominal current	I	A	4,9	1,0	1,4
Peak current	$I_{peak}$	A	15,0	1,6	1,8
Nominal power	P	kW	0,091	0,100	0,400
<b>Environment and Standards</b>					
Ambient temperature	$T_{ambient}$	°C	0...+50	0...+50	0...+50
Degree of protection	IP	–	54S	54S	54S
Standards	–	–	ISO 15552	ISO 15552	ISO 15552

## Ordering information

	BG45	1FK7015	1FK7022
Linear unit	see <a href="#">page 12</a>	see <a href="#">page 12</a>	see <a href="#">page 12</a>
Motor	BG45X30PI	1FK7015-5AK71-1SH3	1FK7022-5AK71-1UH3
Adapter	ZBE-375570	ZBE-375530	ZBE-375537

For more information regarding motors and motor adapters, please visit [page 5](#)

### Dimensional drawing

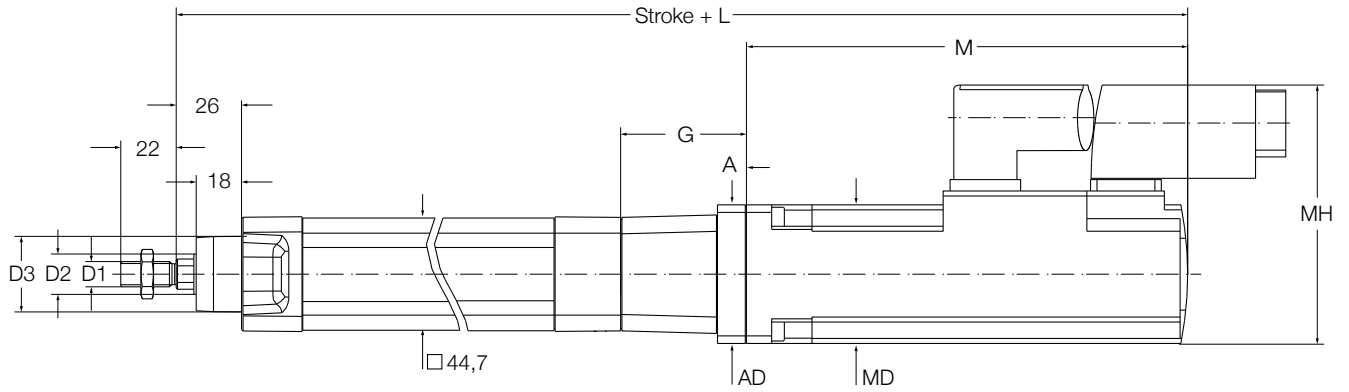

Motor	D1	D2	D3	L	G	A	AD	M	MD	MH
		mm								
BG45	M10 × 1,25	Ø16	Ø30	347,7	39,7	6,7	45,5	160	44	60,8
1FK7015	M10 × 1,25	Ø16	Ø30	353,9	40,9	9	40	165	40	86
1FK7022	M10 × 1,25	Ø16	Ø30	372,4	49,4	11	55	175	55	103

### Performance diagrams

Axial force [N]

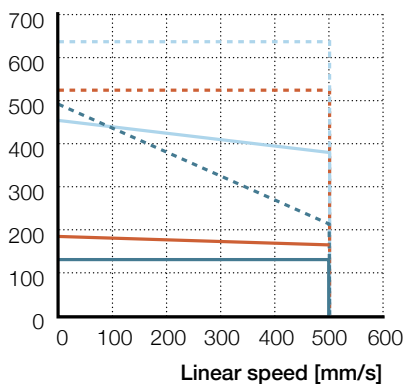

Radial load [N]

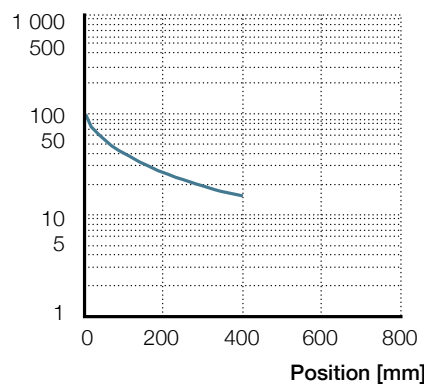

F<sub>m</sub> [N]

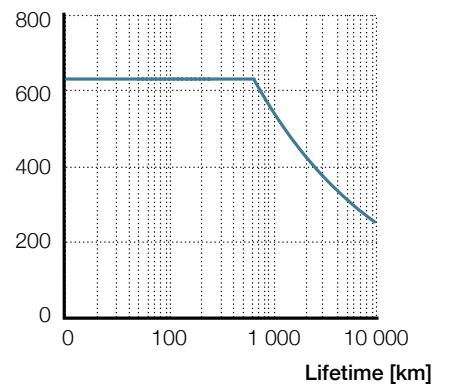

BG45	1FK7015	1FK7022
— F <sub>cont</sub>	— F <sub>cont</sub>	— F <sub>cont</sub>
- - - F <sub>peak</sub>	- - - F <sub>peak</sub>	- - - F <sub>peak</sub>

— CASM-32-BN
--------------

— CASM-32-BN
--------------

### Ordering key

See page 60

# CASM-32-BN

Electric cylinder motor,  
parallel configuration



## Technical data

Designation	Symbol	Unit	BLDC motor BG45	Servo motor 1FK7015
<b>Performance Data</b>				
Continuous force @ zero speed	$F_{c0}$	kN	0,131	0,183
Continuous force @ max. speed	$F_c$	kN	0,131	0,167
Peak force @ zero speed	$F_{p0}$	kN	0,492	0,523
Peak force @ max. speed	$F_p$	kN	0,201	0,523
Dynamic load capacity	C	kN	2,5	2,5
Holding force (motorbrake option)	$F_{Hold}$	kN	0,131	0,151
Max. linear speed	$v_{max}$	mm/s	500	500
Max. acceleration	$a_{max}$	m/s <sup>2</sup>	6	6
Duty cycle	D	%	100	100
<b>Mechanical Data</b>				
Screw type	–	–	Ball screw	Ball screw
Screw diameter	$d_{screw}$	mm	10	10
Screw lead	$p_{screw}$	mm	10	10
Lead accuracy	–	–	G7	G7
Stroke	s	mm	50...400	50...400
Internal overstroke each side	$s_0$	mm	1	1
Backlash	$s_{backlash}$	mm	0,06	0,06
Gear reduction	i	–	1	1
Efficiency	$\eta$	%	64	57
Inertia @ 0 mm stroke	J	10 <sup>-4</sup> kgm <sup>2</sup>	0,0875	0,1265
$\Delta$ Inertia per 100 mm stroke	$\Delta J$	10 <sup>-4</sup> kgm <sup>2</sup>	0,0047	0,0047
Inertia of optional brake	$J_{brake}$	10 <sup>-4</sup> kgm <sup>2</sup>	0,0000	0,0190
Weight @ 0 mm stroke	m	kg	1,71	2,19
$\Delta$ weight per 100 mm stroke	$\Delta m$	kg	0,34	0,34
Weight of optional brake	$m_{brake}$	kg	0,12	0,10
<b>Electrical Data</b>				
Motor type	–	–	Brushless DC	Servo
Nominal voltage	U	V DC	24	N/A
Nominal current	I	A	4,9	1,0
Peak current	$I_{peak}$	A	15,0	1,6
Nominal power	P	kW	0,091	0,100
<b>Environment and Standards</b>				
Ambient temperature	$T_{ambient}$	°C	0...+50	0...+50
Degree of protection	IP	–	54S	54S
Standards	–	–	ISO 15552	ISO 15552

## Ordering information

	BG45	1FK7015
Linear unit	see <b>page 12</b>	see <b>page 12</b>
Motor	BG45X30PI	1FK7015-5AK71-1SH3
Adapter	ZBE-375573	ZBE-375540

For more information regarding motors and motor adapters, please visit **page 5**

### Dimensional drawing

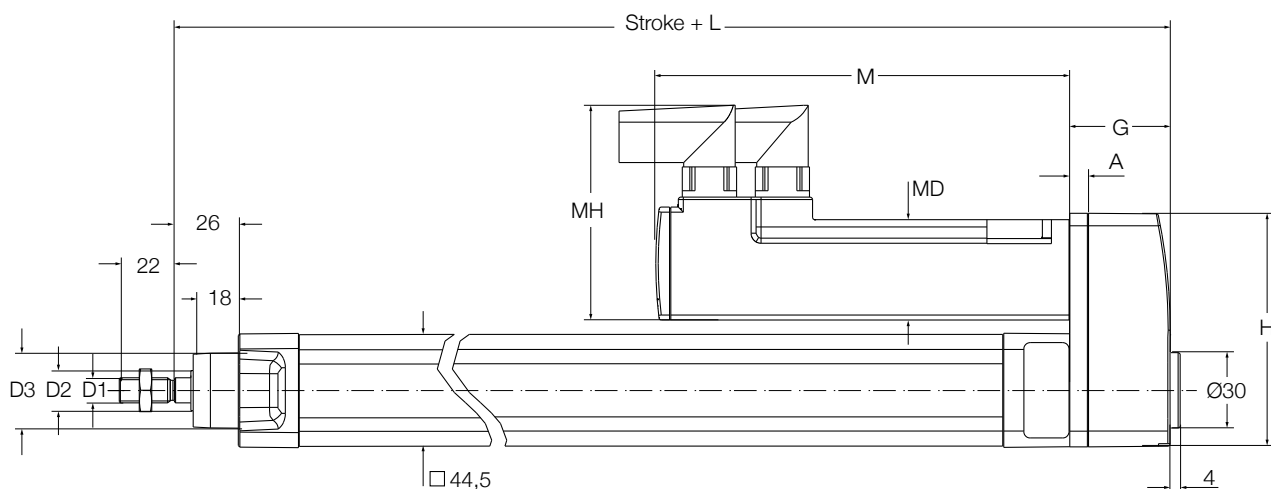

Motor	D1	D2 mm	D3	L	G	A	H	M	MD	MH
BG45	M10 × 1,25	Ø16	Ø30	187,5	39,5	7	93,3	160	44	60,8
1FK7015	M10 × 1,25	Ø16	Ø30	188,1	40,1	7	93,3	165	40	86

### Performance diagrams

Axial force [N]

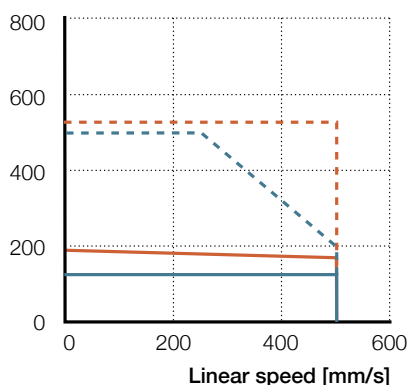

Radial load [N]

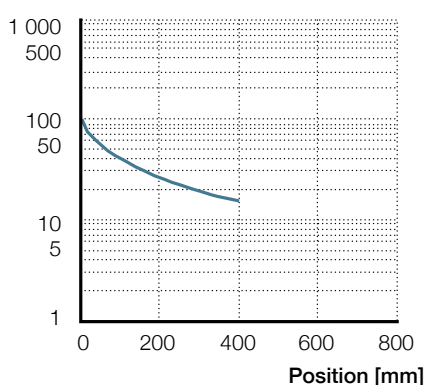

F<sub>m</sub> [N]

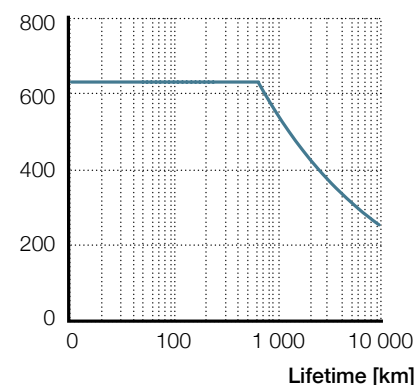

BG45 1FK7015  
 — F<sub>cont</sub> - - F<sub>peak</sub> — F<sub>cont</sub> - - F<sub>peak</sub>

— CASM-32-BN

— CASM-32-BN

### Ordering key

See page 60

# CASM-40-LS

Electric cylinder motor,  
inline configuration



## Technical data

Designation	Symbol	Unit	BLDC motor BG65S	Servo motor 1FK7022
<b>Performance Data</b>				
Continuous force @ zero speed	$F_{c0}$	kN	0,600	0,600
Continuous force @ max. speed	$F_c$	kN	0,071	0,071
Peak force @ zero speed	$F_{p0}$	kN	0,600	0,600
Peak force @ max. speed	$F_p$	kN	0,600	0,600
Dynamic load capacity	C	kN	N/A	N/A
Holding force (motorbrake option)	$F_{Hold}$	kN	–	–
Max. linear speed	$v_{max}$	mm/s	70	70
Max. acceleration	$a_{max}$	m/s <sup>2</sup>	1	1
Duty cycle	D	%	60	60
<b>Mechanical Data</b>				
Screw type	–	–	Lead screw	Lead screw
Screw diameter	$d_{screw}$	mm	12,5	12,5
Screw lead	$p_{screw}$	mm	2,5	2,5
Lead accuracy	–	–	N/A	N/A
Stroke	s	mm	100...600	100...600
Internal overstroke each side	$s_0$	mm	1	1
Backlash	$s_{backlash}$	mm	N/A	N/A
Gear reduction	i	–	1	1
Efficiency	$\eta$	%	32	33
Inertia @ 0 mm stroke	J	10 <sup>-4</sup> kgm <sup>2</sup>	0,2612	0,4122
$\Delta$ Inertia per 100 mm stroke	$\Delta J$	10 <sup>-4</sup> kgm <sup>2</sup>	0,0123	0,0123
Inertia of optional brake	$J_{brake}$	10 <sup>-4</sup> kgm <sup>2</sup>	0,0000	0,0700
Weight @ 0 mm stroke	m	kg	3,22	3,35
$\Delta$ weight per 100 mm stroke	$\Delta m$	kg	0,46	0,46
Weight of optional brake	$m_{brake}$	kg	0,50	0,20
<b>Electrical Data</b>				
Motor type	–	–	Brushless DC	Servo
Nominal voltage	U	V DC	40	N/A
Nominal current	I	A	7,0	1,4
Peak current	$I_{peak}$	A	20,0	1,8
Nominal power	P	kW	0,236	0,400
<b>Environment and Standards</b>				
Ambient temperature	$T_{ambient}$	°C	0...+50	0...+50
Degree of protection	IP	–	54S	54S
Standards	–	–	ISO 15552	ISO 15552

## Ordering information

	BG65	1FK7022
Linear unit	see <b>page 14</b>	see <b>page 14</b>
Motor	BG65SX50PI	1FK7022-5AK71-1UH3
Adapter	ZBE-375571	ZBE-375538

For more information regarding motors and motor adapters, please visit **page 5**



### Dimensional drawing

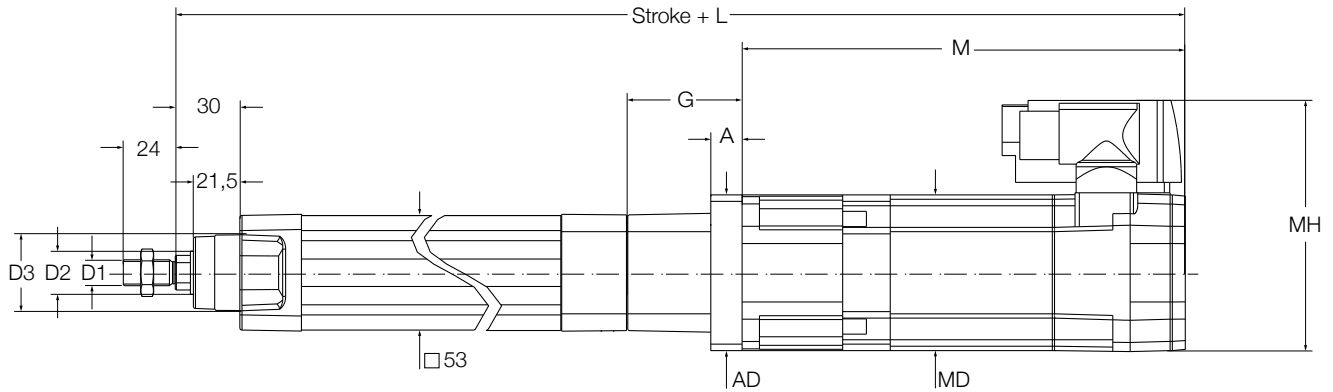

Motor	D1	D2 mm	D3	L	G	A	AD	M	MD	MH
BG65S	M12 × 1,25	Ø20	Ø35	431	53,5	35	54	201	65	96,5
1FK7022	M12 × 1,25	Ø20	Ø35	400,9	49,4	11	64	175	55	103

### Performance diagrams

Axial force [N]

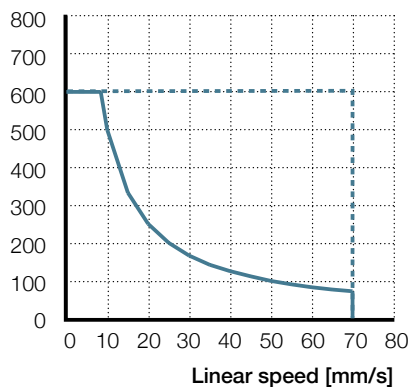

Radial load [N]

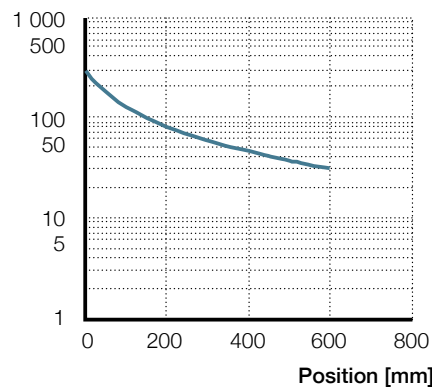

F<sub>m</sub> [N]

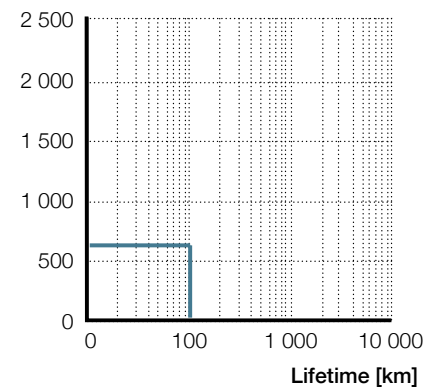

BG65S – 1FK7022

— F<sub>cont</sub>    - - - F<sub>peak</sub>

— CASM-40-LS

— CASM-40-LS

### Ordering key

See page 60

# CASM-40-LS

Electric cylinder motor,  
parallel configuration



## Technical data

Designation	Symbol	Unit	BLDC motor BG65S	Servo motor 1FK7022
<b>Performance Data</b>				
Continuous force @ zero speed	$F_{c0}$	kN	0,596	0,600
Continuous force @ max. speed	$F_c$	kN	0,071	0,071
Peak force @ zero speed	$F_{p0}$	kN	0,600	0,600
Peak force @ max. speed	$F_p$	kN	0,600	0,600
Dynamic load capacity	C	kN	N/A	N/A
Holding force (motorbrake option)	$F_{Hold}$	kN	–	–
Max. linear speed	$v_{max}$	mm/s	70	70
Max. acceleration	$a_{max}$	m/s <sup>2</sup>	1	1
Duty cycle	D	%	60	60
<b>Mechanical Data</b>				
Screw type	–	–	Lead screw	Lead screw
Screw diameter	$d_{screw}$	mm	12,5	12,5
Screw lead	$p_{screw}$	mm	2,5	2,5
Lead accuracy	–	–	N/A	N/A
Stroke	s	mm	100...600	100...600
Internal overstroke each side	$s_0$	mm	1	1
Backlash	$s_{backlash}$	mm	N/A	N/A
Gear reduction	i	–	1	1
Efficiency	$\eta$	%	32	32
Inertia @ 0 mm stroke	J	10 <sup>-4</sup> kgm <sup>2</sup>	0,2641	0,4151
$\Delta$ Inertia per 100 mm stroke	$\Delta J$	10 <sup>-4</sup> kgm <sup>2</sup>	0,0123	0,0123
Inertia of optional brake	$J_{brake}$	10 <sup>-4</sup> kgm <sup>2</sup>	0,0000	0,0700
Weight @ 0 mm stroke	m	kg	3,32	3,45
$\Delta$ weight per 100 mm stroke	$\Delta m$	kg	0,46	0,46
Weight of optional brake	$m_{brake}$	kg	0,50	0,20
<b>Electrical Data</b>				
Motor type	–	–	Brushless DC	Servo
Nominal voltage	U	V DC	40	N/A
Nominal current	I	A	7,0	1,4
Peak current	$I_{peak}$	A	20,0	1,8
Nominal power	P	kW	0,236	0,400
<b>Environment and Standards</b>				
Ambient temperature	$T_{ambient}$	°C	0...+50	0...+50
Degree of protection	IP	–	54S	54S
Standards	–	–	ISO 15552	ISO 15552

## Ordering information

	BG65S	1FK7022
Linear unit	see <a href="#">page 14</a>	see <a href="#">page 14</a>
Motor	BG65SX50PI	1FK7022-5AK71-1UH3
Adapter	ZBE-375574	ZBE-375546

For more information regarding motors and motor adapters, please visit [page 5](#)

### Dimensional drawing

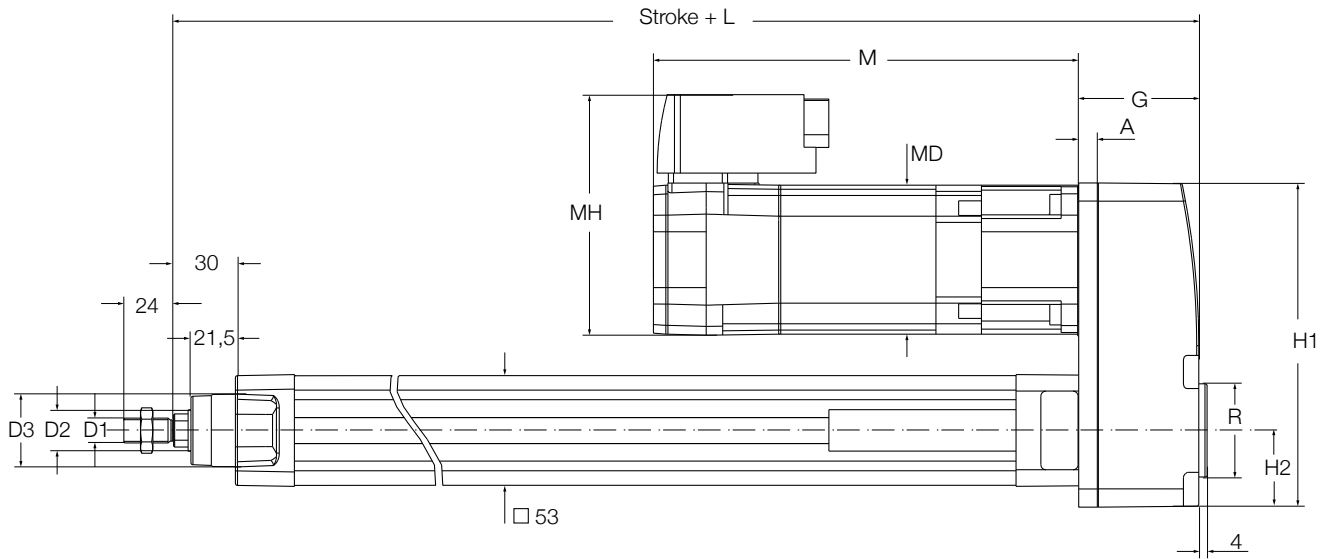

Motor	D1	D2	D3	L	G	A	H1	H2	M	MD	MH	R
BG65S	M12 × 1,25	Ø20	Ø35	223	46,5	7	115,3	26,8	201	65	96,5	Ø35
1FK7022	M12 × 1,25	Ø20	Ø35	223,6	47,1	7	115,3	26,8	175	55	103	Ø35

### Performance diagrams

Axial force [N]

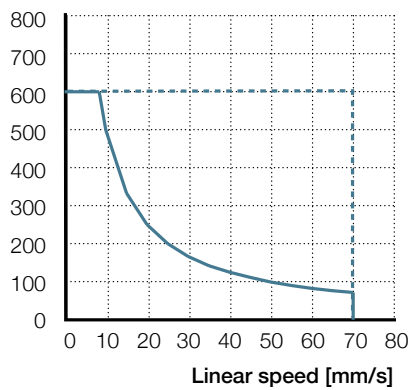

Radial load [N]

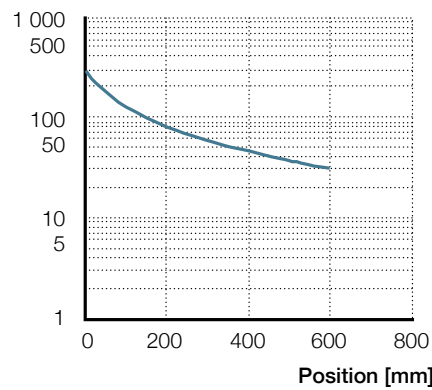

$F_m$  [N]

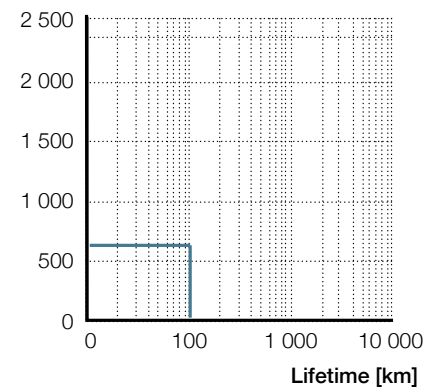

BG65S – 1FK7022

—  $F_{cont}$     - - -  $F_{peak}$

— CASM-40-LS

— CASM-40-LS

### Ordering key

See page 60

# CASM-40-BS

Electric cylinder motor,  
inline configuration



## Technical data

Designation	Symbol	Unit	BLDC motor BG65S	BLDC motor BG75	Servo motor 1FK7022	Servo motor 1FK7034
<b>Performance Data</b>						
Continuous force @ zero speed	$F_{c0}$	kN	0,673	1,239	0,908	1,709
Continuous force @ max. speed	$F_c$	kN	0,673	1,239	0,758	1,485
Peak force @ zero speed	$F_{p0}$	kN	1,805	2,375	2,375	2,375
Peak force @ max. speed	$F_p$	kN	0,673	1,453	2,375	2,375
Dynamic load capacity	C	kN	4,8	4,8	4,8	4,8
Holding force (motorbrake option)	$F_{Hold}$	kN	1,478	1,478	1,478	2,375
Max. linear speed	$v_{max}$	mm/s	298	300	300	300
Max. acceleration	$a_{max}$	m/s <sup>2</sup>	6	6	6	6
Duty cycle	D	%	100	100	100	100
<b>Mechanical Data</b>						
Screw type	–	–	Ball screw	Ball screw	Ball screw	Ball screw
Screw diameter	$d_{screw}$	mm	12	12	12	12
Screw lead	$p_{screw}$	mm	5	5	5	5
Lead accuracy	–	–	G7	G7	G7	G7
Stroke	s	mm	100...600	100...600	100...600	100...600
Internal overstroke each side	$s_0$	mm	1	1	1	1
Backlash	$s_{backlash}$	mm	0,07	0,07	0,07	0,07
Gear reduction	i	–	1	1	1	1
Efficiency	$\eta$	%	72	77	73	75
Inertia @ 0 mm stroke	J	10 <sup>-4</sup> kgm <sup>2</sup>	0,2596	0,7826	0,4106	1,0306
$\Delta$ Inertia per 100 mm stroke	$\Delta J$	10 <sup>-4</sup> kgm <sup>2</sup>	0,0103	0,0103	0,0103	0,0103
Inertia of optional brake	$J_{brake}$	10 <sup>-4</sup> kgm <sup>2</sup>	0	0,0000	0,0700	0,1000
Weight @ 0 mm stroke	m	kg	3,23	4,36	3,36	5,06
$\Delta$ weight per 100 mm stroke	$\Delta m$	kg	0,46	0,46	0,46	0,46
Weight of optional brake	$m_{brake}$	kg	0,5	0,50	0,20	0,40
<b>Electrical Data</b>						
Motor type	–	–	Brushless DC	Brushless DC	Servo	Servo
Nominal voltage	U	V DC	40	40	N/A	N/A
Nominal current	I	A	7	12,7	1,4	1,3
Peak current	$I_{peak}$	A	20	50,0	1,8	1,9
Nominal power	P	kW	0,236	0,450	0,400	0,600
<b>Environment and Standards</b>						
Ambient temperature	$T_{ambient}$	°C	0...+50	0...+50	0...+50	0...+50
Degree of protection	IP	–	54S	54S	54S	54S
Standards	–	–	ISO 15552	ISO 15552	ISO 15552	ISO 15552

## Ordering information

	BG65	BG75	1FK7022	1FK7034
Linear unit	see <a href="#">page 14</a>	see <a href="#">page 14</a>	see <a href="#">page 14</a>	see <a href="#">page 14</a>
Motor	BG65SX50PI	BG75X75PI	1FK7022-5AK71-1UH3	1FK7034-2AK71-1UH0
Adapter	ZBE-375571	ZBE-375579	ZBE-375538	ZBE-375545

For more information regarding motors and motor adapters, please visit [page 5](#)

### Dimensional drawing

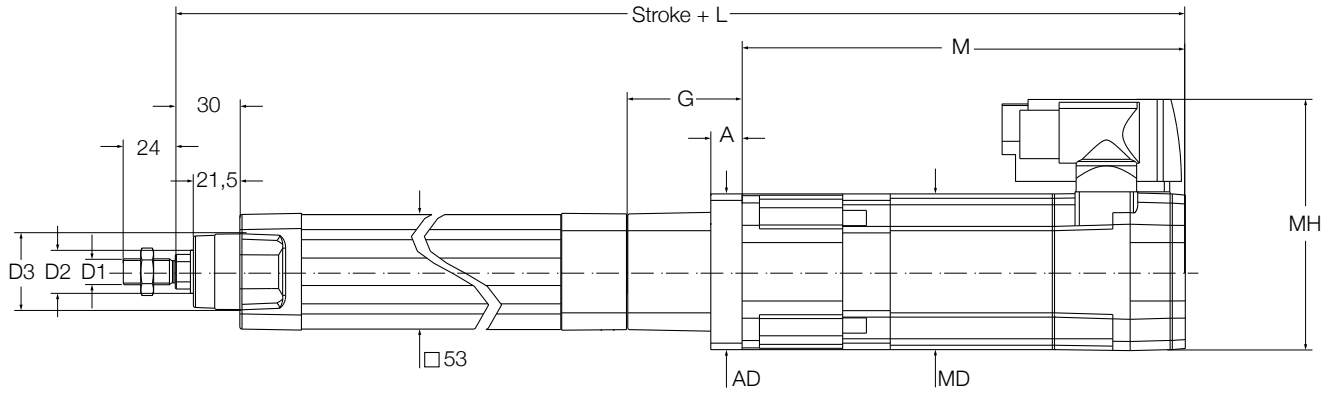

Motor	D1	D2 mm	D3	L	G	A	AD	M	MD	MH
BG65S	M12 × 1,25	Ø20	Ø35	431	53,5	35	54	201	65	96,5
BG75	M12 × 1,25	Ø20	Ø35	462,9	52,4	14	75	234	75	100
1FK7022	M12 × 1,25	Ø20	Ø35	400,9	49,4	11	64	175	55	103
1FK7034	M12 × 1,25	Ø20	Ø35	428,9	52,4	14	72	200	72	117

### Performance diagrams

Axial force [N]

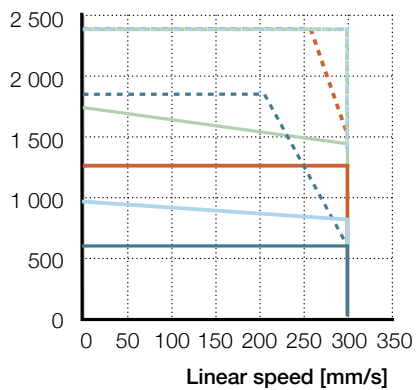

Radial load [N]

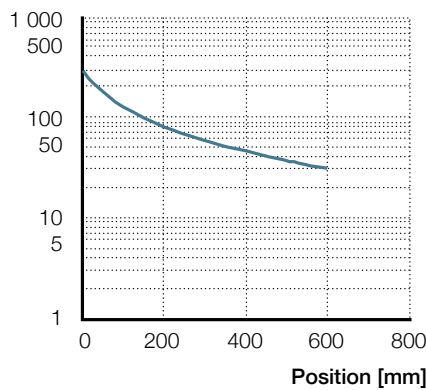

F<sub>m</sub> [N]

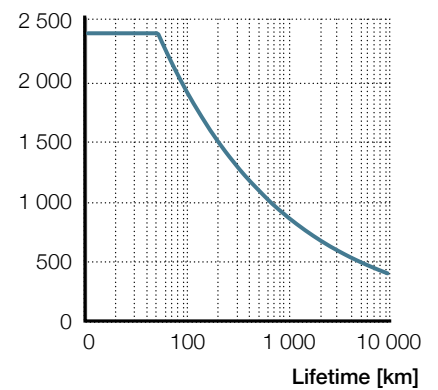

BG65S	BG75	1FK7022	1FK7034
— F <sub>cont</sub>	— F <sub>cont</sub>	— F <sub>cont</sub>	— F <sub>cont</sub>
- - - F <sub>peak</sub>	- - - F <sub>peak</sub>	- - - F <sub>peak</sub>	- - - F <sub>peak</sub>

— CASM-40-BS

— CASM-40-BS

### Ordering key

See page 60

# CASM-40-BS

Electric cylinder motor,  
parallel configuration



## Technical data

Designation	Symbol	Unit	BLDC motor BG65S	BLDC motor BG75	Servo motor 1FK7022	Servo motor 1FK7034
<b>Performance Data</b>						
Continuous force @ zero speed	$F_{c0}$	kN	0,666	1,227	0,899	1,692
Continuous force @ max. speed	$F_c$	kN	0,666	1,227	0,751	1,47
Peak force @ zero speed	$F_{p0}$	kN	1,787	2,375	2,375	2,375
Peak force @ max. speed	$F_p$	kN	0,666	1,438	2,375	2,375
Dynamic load capacity	C	kN	4,8	4,8	4,8	4,8
Holding force (motorbrake option)	$F_{Hold}$	kN	1,478	1,478	1,478	2,375
Max. linear speed	$v_{max}$	mm/s	298	300	300	300
Max. acceleration	$a_{max}$	m/s <sup>2</sup>	6	6	6	6
Duty cycle	D	%	100	100	100	100
<b>Mechanical Data</b>						
Screw type	–	–	Ball screw	Ball screw	Ball screw	Ball screw
Screw diameter	$d_{screw}$	mm	12	12	12	12
Screw lead	$p_{screw}$	mm	5	5	5	5
Lead accuracy	–	–	G7	G7	G7	G7
Stroke	s	mm	100...600	100...600	100...600	100...600
Internal overstroke each side	$s_0$	mm	1	1	1	1
Backlash	$s_{backlash}$	mm	0,07	0,07	0,07	0,07
Gear reduction	i	–	1	1	1	1
Efficiency	$\eta$	%	72	76	72	74
Inertia @ 0 mm stroke	J	10 <sup>-4</sup> kgm <sup>2</sup>	0,2624	0,8314	0,4134	1,0794
Δ Inertia per 100 mm stroke	ΔJ	10 <sup>-4</sup> kgm <sup>2</sup>	0,0103	0,0103	0,0103	0,0103
Inertia of optional brake	$J_{brake}$	10 <sup>-4</sup> kgm <sup>2</sup>	0	0,0000	0,0700	0,1000
Weight @ 0 mm stroke	m	kg	3,33	4,51	3,46	5,21
Δ weight per 100 mm stroke	Δm	kg	0,46	0,46	0,46	0,46
Weight of optional brake	$m_{brake}$	kg	0,5	0,50	0,20	0,40
<b>Electrical Data</b>						
Motor type	–	–	Brushless DC	Brushless DC	Servo	Servo
Nominal voltage	U	V DC	40	40	N/A	N/A
Nominal current	I	A	7	12,7	1,4	1,3
Peak current	$I_{peak}$	A	20	50,0	1,8	1,9
Nominal power	P	kW	0,236	0,450	0,400	0,600
<b>Environment and Standards</b>						
Ambient temperature	$T_{ambient}$	°C	0...+50	0...+50	0...+50	0...+50
Degree of protection	IP	–	54S	54S	54S	54S
Standards	–	–	ISO 15552	ISO 15552	ISO 15552	ISO 15552

## Ordering information

	BG65S	BG75	1FK7022	1FK7034
Linear unit	see page 14	see page 14	see page 14	see page 14
Motor	BG65SX50PI	BG75X75PI	1FK7022-5AK71-1UH3	1FK7034-2AK71-1UH0
Adapter	ZBE-375574	ZBE-375578	ZBE-375546	ZBE-375603

For more information regarding motors and motor adapters, please visit [page 5](#)

### Dimensional drawing

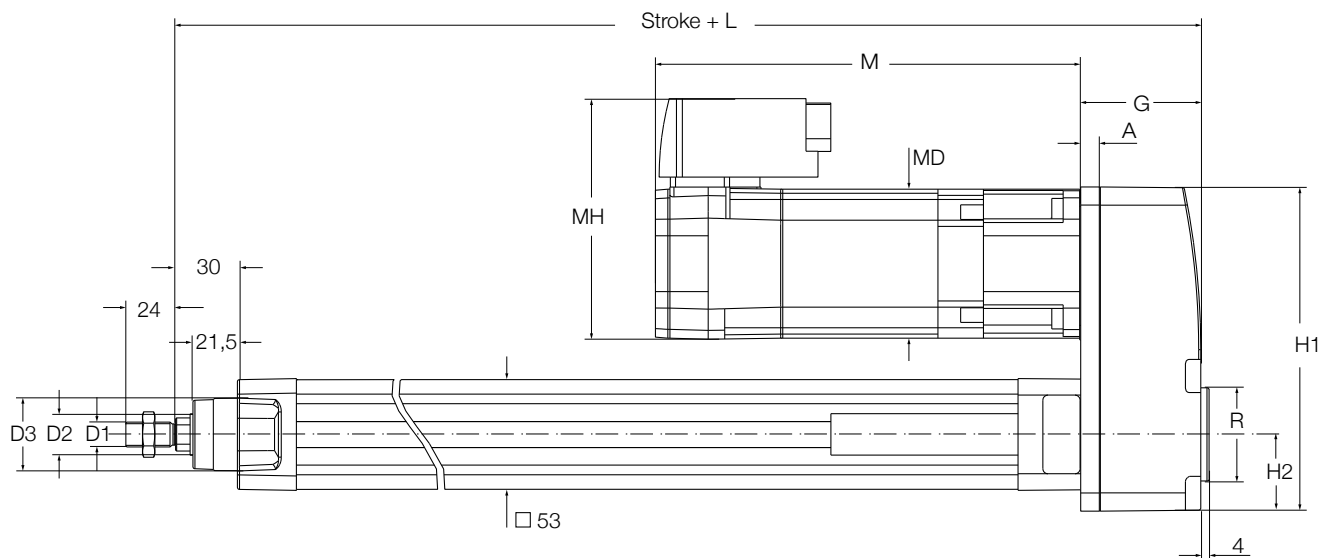

Motor	D1	D2	D3	L	G	A	H1	H2	M	MD	MH	R
		mm										
BG65S	M12 × 1,25	Ø20	Ø35	223	46,5	7	115,3	26,8	201	65	96,5	Ø35
BG75	M12 × 1,25	Ø20	Ø35	234,5	58	7	156,6	37,05	234	75	100	Ø45
1FK7022	M12 × 1,25	Ø20	Ø35	223,6	47,1	7	115,3	26,8	175	65	103	Ø35
1FK7034	M12 × 1,25	Ø20	Ø35	234,6	58,1	9	157,3	37,05	200	72	117	Ø45

### Performance diagrams

Axial force [N]

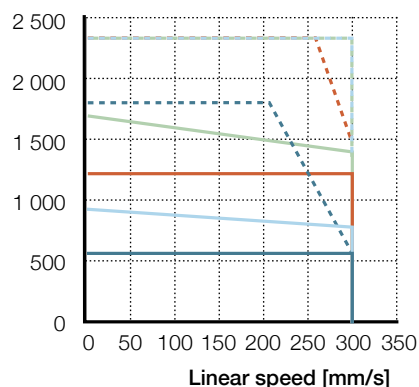

Radial load [N]

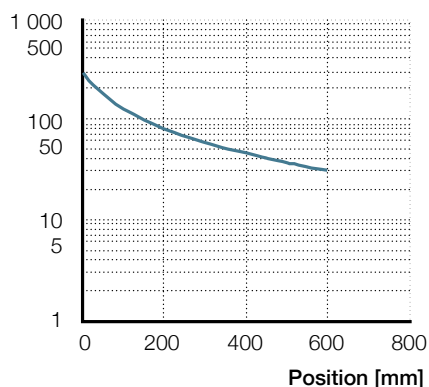

F<sub>m</sub> [N]

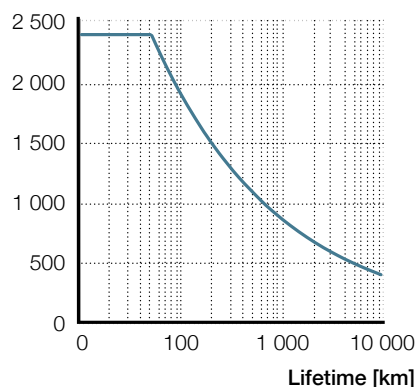

BG65S	BG75	1FK7022	1FK7034
— F <sub>cont</sub>	— F <sub>cont</sub>	— F <sub>cont</sub>	— F <sub>cont</sub>
- - - F <sub>peak</sub>	- - - F <sub>peak</sub>	- - - F <sub>peak</sub>	- - - F <sub>peak p</sub>

— CASM-40-BS
--------------

— CASM-40-BS
--------------

### Ordering key

See page 60

# CASM-40-BN

Electric cylinder motor,  
inline configuration



## Technical data

Designation	Symbol	Unit	BLDC motor BG65S	BLDC motor BG75	Servo motor 1FK7022	Servo motor 1FK7034
<b>Performance Data</b>						
Continuous force @ zero speed	$F_{c0}$	kN	0,268	0,494	0,362	0,681
Continuous force @ max. speed	$F_c$	kN	0,268	0,494	0,302	0,574
Peak force @ zero speed	$F_{p0}$	kN	0,719	1,550	1,447	1,550
Peak force @ max. speed	$F_p$	kN	0,268	0,494	1,447	1,550
Dynamic load capacity	C	kN	6	6	6	6
Holding force (motorbrake option)	$F_{Hold}$	kN	0,575	0,575	0,575	1,093
Max. linear speed	$v_{max}$	mm/s	756	783	826	826
Max. acceleration	$a_{max}$	m/s <sup>2</sup>	6	6	6	6
Duty cycle	D	%	100	100	100	100
<b>Mechanical Data</b>						
Screw type	–	–	Ball screw	Ball screw	Ball screw	Ball screw
Screw diameter	$d_{screw}$	mm	12,7	12,7	12,7	12,7
Screw lead	$p_{screw}$	mm	12,7	12,7	12,7	12,7
Lead accuracy	–	–	G7	G7	G7	G7
Stroke	s	mm	100...600	100...600	100...600	100...600
Internal overstroke each side	$s_0$	mm	1	1	1	1
Backlash	$s_{backlash}$	mm	0,07	0,07	0,07	0,07
Gear reduction	i	–	1	1	1	1
Efficiency	$\eta$	%	73	77	74	76
Inertia @ 0 mm stroke	J	10 <sup>-4</sup> kgm <sup>2</sup>	0,2629	0,7859	0,4139	1,0339
Δ Inertia per 100 mm stroke	ΔJ	10 <sup>-4</sup> kgm <sup>2</sup>	0,0144	0,0144	0,0144	0,0144
Inertia of optional brake	$J_{brake}$	10 <sup>-4</sup> kgm <sup>2</sup>	0	0,0000	0,0700	0,1000
Weight @ 0 mm stroke	m	kg	3,26	4,39	3,39	5,09
Δ weight per 100 mm stroke	Δm	kg	0,46	0,46	0,46	0,46
Weight of optional brake	$m_{brake}$	kg	0,5	0,50	0,20	0,4
<b>Electrical Data</b>						
Motor type	–	–	Brushless DC	Brushless DC	Servo	Servo
Nominal voltage	U	V DC	40	40	N/A	N/A
Nominal current	I	A	7	12,7	1,4	1,3
Peak current	$I_{peak}$	A	20	50,0	1,8	1,9
Nominal power	P	kW	0,236	0,450	0,400	0,600
<b>Environment and Standards</b>						
Ambient temperature	$T_{ambient}$	°C	0...+50	0...+50	0...+50	0...+50
Degree of protection	IP	–	54S	54S	54S	54S
Standards	–	–	ISO 15552	ISO 15552	ISO 15552	ISO 15552

## Ordering information

	BG65S	BG75	1FK7022	1FK7034
Linear unit	see <a href="#">page 14</a>	see <a href="#">page 14</a>	see <a href="#">page 14</a>	see <a href="#">page 14</a>
Motor	BG65SX50PI	BG75X75PI	1FK7022-5AK71-1UH3	1FK7034-2AK71-1UH0
Adapter	ZBE-375571	ZBE-375579	ZBE-375538	ZBE-375545

For more information regarding motors and motor adapters, please visit [page 5](#)



### Dimensional drawing

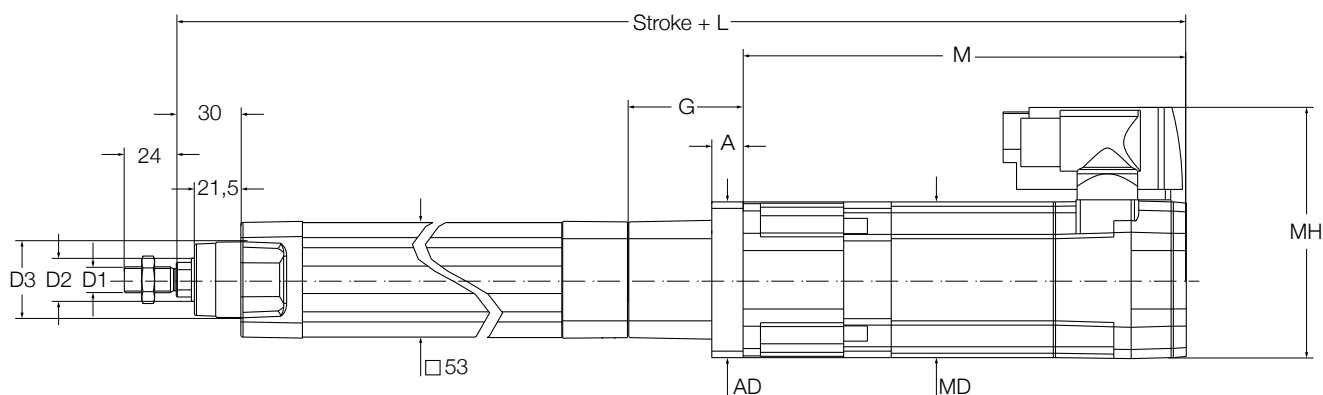

Motor	D1	D2	D3	L	G	A	AD	M	MD	MH
		mm								
BG65S	M12 × 1,25	Ø20	Ø35	431	53,5	35	54	201	65	96,5
BG75	M12 × 1,25	Ø20	Ø35	462,9	52,4	14	75	234	75	100
1FK7022	M12 × 1,25	Ø20	Ø35	400,9	49,4	11	64	175	55	103
1FK7034	M12 × 1,25	Ø20	Ø35	428,9	52,4	14	72	200	72	117

### Performance diagrams

Axial force [N]

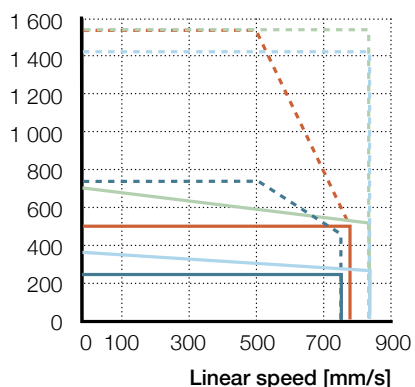

Radial load [N]

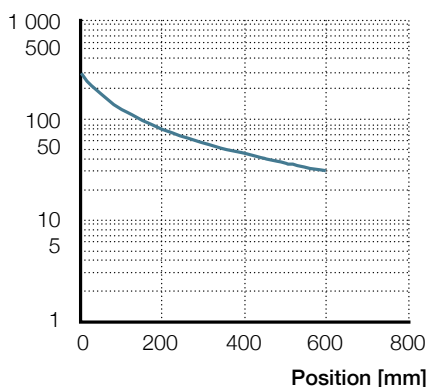

F<sub>m</sub> [N]

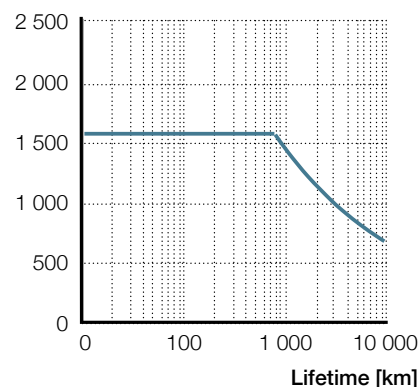

BG65S BG75 1FK7022 1FK7034

— F<sub>cont</sub> — F<sub>peak</sub> — F<sub>cont</sub> — F<sub>peak</sub> — F<sub>cont</sub> — F<sub>peak</sub> — F<sub>cont</sub> — F<sub>peak</sub>

— CASM-40-BN

— CASM-40-BN

### Ordering key

See page 60

# CASM-40-BN

Electric cylinder motor,  
parallel configuration



## Technical data

Designation	Symbol	Unit	BLDC motor BG65S	BLDC motor BG75	Servo motor 1FK7022	Servo motor 1FK7034
<b>Performance Data</b>						
Continuous force @ zero speed	$F_{c0}$	kN	0,265	0,489	0,358	0,674
Continuous force @ max. speed	$F_c$	kN	0,265	0,489	0,299	0,569
Peak force @ zero speed	$F_{p0}$	kN	0,712	1,276	1,276	1,276
Peak force @ max. speed	$F_p$	kN	0,265	0,489	1,276	1,276
Dynamic load capacity	C	kN	6	6	6	6
Holding force (motorbrake option)	$F_{Hold}$	kN	0,575	0,575	0,575	1,093
Max. linear speed	$v_{max}$	mm/s	756	783	826	826
Max. acceleration	$a_{max}$	m/s <sup>2</sup>	6	6	6	6
Duty cycle	D	%	100	100	100	100
<b>Mechanical Data</b>						
Screw type	–	–	Ball screw	Ball screw	Ball screw	Ball screw
Screw diameter	$d_{screw}$	mm	12,7	12,7	12,7	12,7
Screw lead	$p_{screw}$	mm	12,7	12,7	12,7	12,7
Lead accuracy	–	–	G7	G7	G7	G7
Stroke	s	mm	100...600	100...600	100...600	100...600
Internal overstroke each side	$s_0$	mm	1	1	1	1
Backlash	$s_{backlash}$	mm	0,07	0,07	0,07	0,07
Gear reduction	i	–	1	1	1	1
Efficiency	$\eta$	%	72	77	73	75
Inertia @ 0 mm stroke	J	10 <sup>-4</sup> kgm <sup>2</sup>	0,2657	0,8347	0,4167	1,0827
Δ Inertia per 100 mm stroke	ΔJ	10 <sup>-4</sup> kgm <sup>2</sup>	0,0144	0,0144	0,0144	0,0144
Inertia of optional brake	$J_{brake}$	10 <sup>-4</sup> kgm <sup>2</sup>	0	0,0000	0,0700	0,1000
Weight @ 0 mm stroke	m	kg	3,36	4,54	3,49	5,24
Δ weight per 100 mm stroke	Δm	kg	0,46	0,46	0,46	0,46
Weight of optional brake	$m_{brake}$	kg	0,5	0,50	0,20	0,40
<b>Electrical Data</b>						
Motor type	–	–	Brushless DC	Brushless DC	Servo	Servo
Nominal voltage	U	V DC	40	40	N/A	N/A
Nominal current	I	A	7	12,7	1,4	1,3
Peak current	$I_{peak}$	A	20	50,0	1,8	1,9
Nominal power	P	kW	0,236	0,450	0,400	0,600
<b>Environment and Standards</b>						
Ambient temperature	$T_{ambient}$	°C	0...+50	0...+50	0...+50	0...+50
Degree of protection	IP	–	54S	54S	54S	54S
Standards	–	–	ISO 15552	ISO 15552	ISO 15552	ISO 15552

## Ordering information

	BG65S	BG75	1FK7022	1FK7034
Linear unit	see <a href="#">page 14</a>	see <a href="#">page 14</a>	see <a href="#">page 14</a>	see <a href="#">page 14</a>
Motor	BG65SX50PI	BG75X75PI	1FK7022-5AK71-1UH3	1FK7034-2AK71-1UH0
Adapter	ZBE-375574	ZBE-375578	ZBE-375546	ZBE-375603

For more information regarding motors and motor adapters, please visit [page 5](#)

### Dimensional drawing

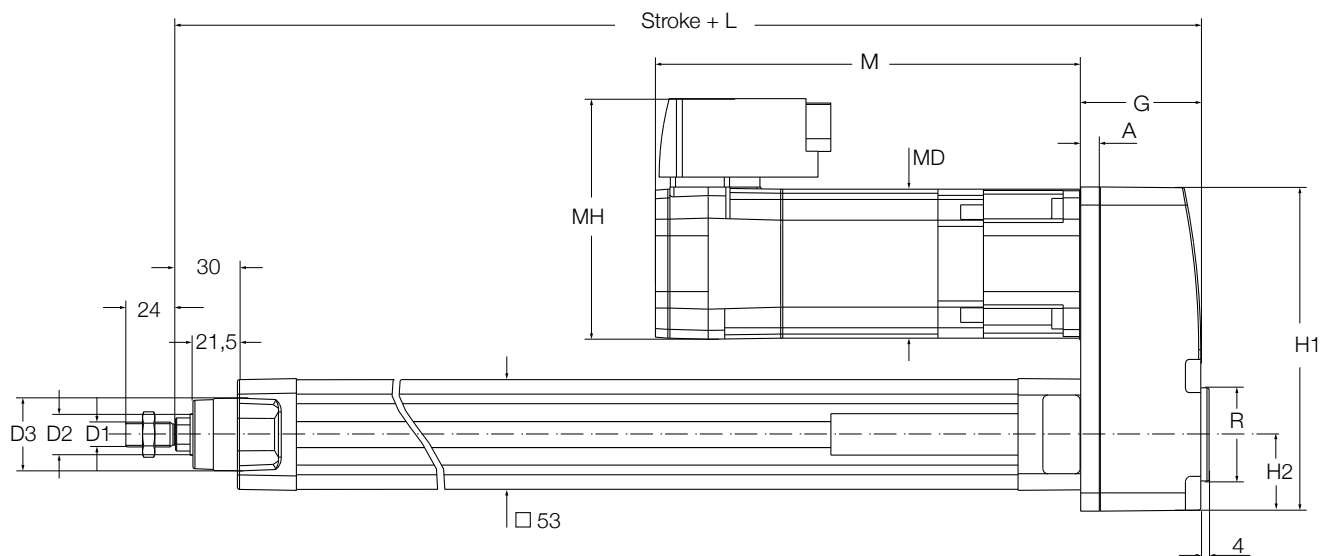

Motor	D1	D2	D3	L	G	A	H1	H2	M	MD	MH	R
		mm										
BG65S	M12 × 1,25	Ø20	Ø35	223	46.5	7	115,3	26,8	201	65	96,5	Ø35
BG75	M12 × 1,25	Ø20	Ø35	234,5	58	7	156,6	37,05	234	75	100	Ø45
1FK7022	M12 × 1,25	Ø20	Ø35	223,6	47.1	7	115,3	26,8	175	55	103	Ø35
1FK7034	M12 × 1,25	Ø20	Ø35	234,6	58.1	9	157,3	37,05	200	72	117	Ø45

### Performance diagrams

Axial force [N]

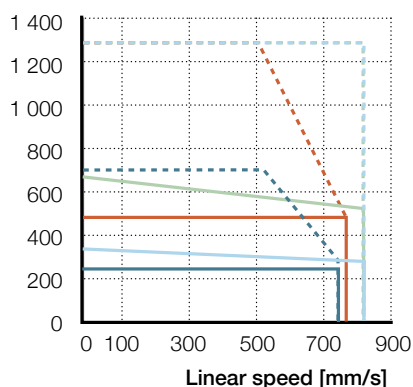

Radial load [N]

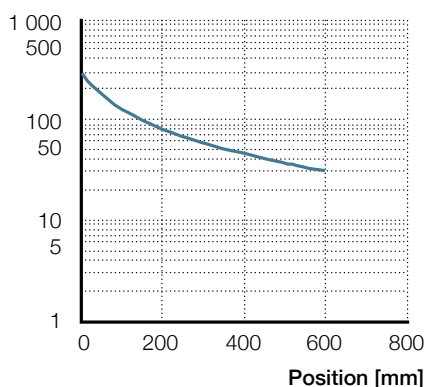

F<sub>m</sub> [N]

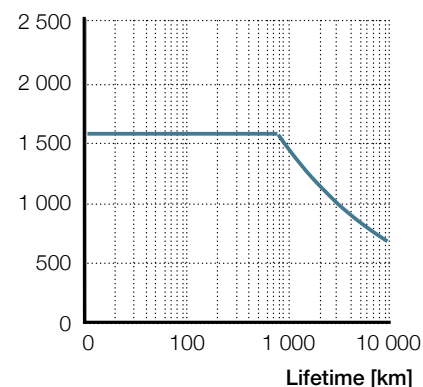

BG65S	BG75	1FK7022	1FK7034
— F <sub>cont</sub>	— F <sub>cont</sub>	— F <sub>cont</sub>	— F <sub>cont</sub>
- - - F <sub>peak</sub>	- - - F <sub>peak</sub>	- - - F <sub>peak</sub>	- - - F <sub>peak</sub>

— CASM-40-BN

— CASM-40-BN

### Ordering key

See page 60

# CASM-63-LS

Electric cylinder motor,  
inline configuration



## Technical data

Designation	Symbol	Unit	BLDC motor BG75	Servo motor 1FK7034
<b>Performance Data</b>				
Continuous force @ zero speed	$F_{c0}$	kN	0,711	0,980
Continuous force @ max. speed	$F_c$	kN	0,114	0,114
Peak force @ zero speed	$F_{p0}$	kN	1,000	1,000
Peak force @ max. speed	$F_p$	kN	1,000	1,000
Dynamic load capacity	$C$	kN	N/A	N/A
Holding force (motorbrake option)	$F_{Hold}$	kN	–	–
Max. linear speed	$v_{max}$	mm/s	70	70
Max. acceleration	$a_{max}$	m/s <sup>2</sup>	1	1
Duty cycle	$D$	%	60	60
<b>Mechanical Data</b>				
Screw type	–	–	Lead screw	Lead screw
Screw diameter	$d_{screw}$	mm	20	20
Screw lead	$p_{screw}$	mm	4	4
Lead accuracy	–	–	N/A	N/A
Stroke	$s$	mm	100...800	100...800
Internal overstroke each side	$s_0$	mm	1	1
Backlash	$s_{backlash}$	mm	N/A	N/A
Gear reduction	$i$	–	1	1
Efficiency	$\eta$	%	35	34
Inertia @ 0 mm stroke	$J$	10 <sup>-4</sup> kgm <sup>2</sup>	1,6120	1,8600
Δ Inertia per 100 mm stroke	$\Delta J$	10 <sup>-4</sup> kgm <sup>2</sup>	0,0809	0,0809
Inertia of optional brake	$J_{brake}$	10 <sup>-4</sup> kgm <sup>2</sup>	0,0000	0,1000
Weight @ 0 mm stroke	$m$	kg	5,95	6,65
Δ weight per 100 mm stroke	$\Delta m$	kg	0,81	0,81
Weight of optional brake	$m_{brake}$	kg	0,50	0,40
<b>Electrical Data</b>				
Motor type	–	–	Brushless DC	Servo
Nominal voltage	$U$	V DC	40	N/A
Nominal current	$I$	A	12,7	1,3
Peak current	$I_{peak}$	A	50,0	1,9
Nominal power	$P$	kW	0,450	0,600
<b>Environment and Standards</b>				
Ambient temperature	$T_{ambient}$	°C	0...+50	0...+50
Degree of protection	IP	–	54S	54S
Standards	–	–	ISO 15552	ISO 15552

## Ordering information

	BG75	1FK7034
Linear unit	see page 16	see page 16
Motor	BG75X75PI	1FK7034-2AK71-1UH0
Adapter	ZBE-375572	ZBE-375544

For more information regarding motors and motor adapters, please visit [page 5](#)

### Dimensional drawing

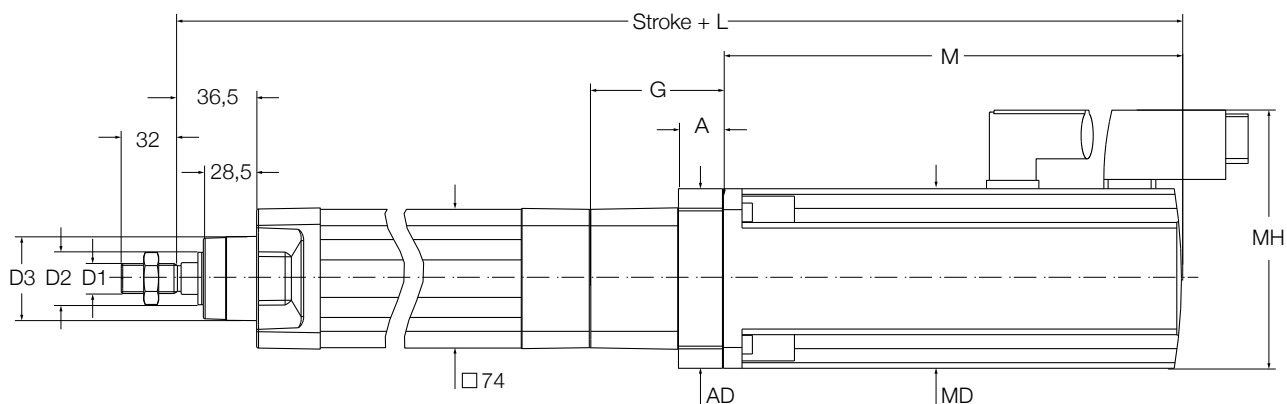

Motor	D1	D2 mm	D3	L	G	A	AD	M	MD	MH
BG75	M16 × 1,5	Ø28	Ø45	515,1	67,1	20	75	234	75	100
1FK7034	M16 × 1,5	Ø28	Ø45	476,4	62,4	15	75	200	72	117

### Performance diagrams

Axial force [N]

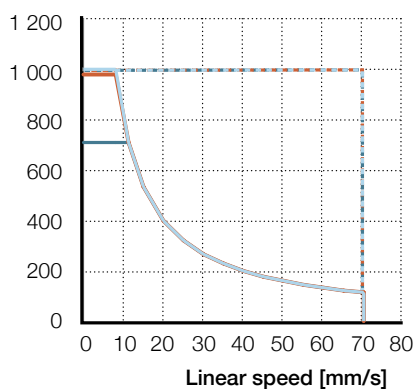

Radial load [N]

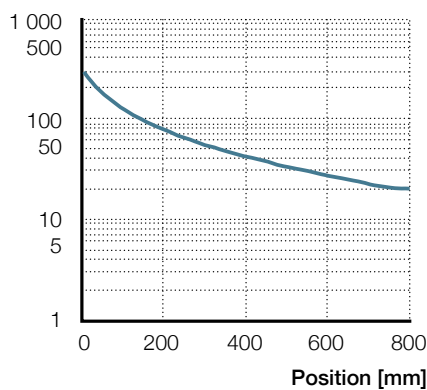

F<sub>m</sub> [N]

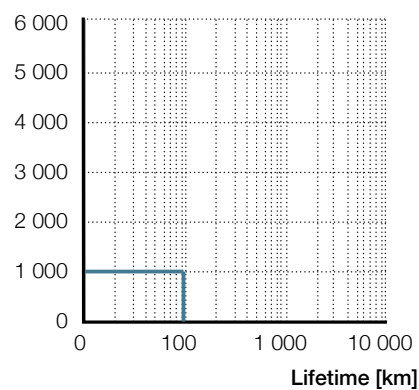

BG75	1FK7034	1FK7034
— F <sub>cont</sub>	— F <sub>cont</sub>	— F <sub>cont</sub>
- - - F <sub>peak</sub>	- - - F <sub>peak</sub>	- - - F <sub>peak</sub>

— CASM-63-LS

— CASM-63-LS

### Ordering key

See page 60

# CASM-63-LS

Electric cylinder motor,  
parallel configuration



## Technical data

Designation	Symbol	Unit	BLDC motor BG75	Servo motor 1FK7034
<b>Performance Data</b>				
Continuous force @ zero speed	$F_{c0}$	kN	0,704	0,970
Continuous force @ max. speed	$F_c$	kN	0,114	0,114
Peak force @ zero speed	$F_{p0}$	kN	1,000	1,000
Peak force @ max. speed	$F_p$	kN	1,000	1,000
Dynamic load capacity	$C$	kN	N/A	N/A
Holding force (motorbrake option)	$F_{Hold}$	kN		
Max. linear speed	$v_{max}$	mm/s	70	70
Max. acceleration	$a_{max}$	m/s <sup>2</sup>	1	1
Duty cycle	$D$	%	60	60
<b>Mechanical Data</b>				
Screw type	–	–	Lead screw	Lead screw
Screw diameter	$d_{screw}$	mm	20	20
Screw lead	$p_{screw}$	mm	4	4
Lead accuracy	–	–	N/A	N/A
Stroke	$s$	mm	100...800	100...800
Internal overstroke each side	$s_0$	mm	1	1
Backlash	$s_{backlash}$	mm	N/A	N/A
Gear reduction	$i$	–	1	1
Efficiency	$\eta$	%	35	34
Inertia @ 0 mm stroke	$J$	10 <sup>-4</sup> kgm <sup>2</sup>	1,4668	1,7148
Δ Inertia per 100 mm stroke	$\Delta J$	10 <sup>-4</sup> kgm <sup>2</sup>	0,0809	0,0809
Inertia of optional brake	$J_{brake}$	10 <sup>-4</sup> kgm <sup>2</sup>	0,0000	0,1000
Weight @ 0 mm stroke	$m$	kg	6,05	6,75
Δ weight per 100 mm stroke	$\Delta m$	kg	0,81	0,81
Weight of optional brake	$m_{brake}$	kg	0,50	0,40
<b>Electrical Data</b>				
Motor type	–	–	Brushless DC	Servo
Nominal voltage	$U$	V DC	40	N/A
Nominal current	$I$	A	12,7	1,3
Peak current	$I_{peak}$	A	50,0	1,9
Nominal power	$P$	kW	0,450	0,600
<b>Environment and Standards</b>				
Ambient temperature	$T_{ambient}$	°C	0...+50	0...+50
Degree of protection	IP	–	54S	54S
Standards	–	–	ISO 15552	ISO 15552

## Ordering information

	BG75	1FK7034
Linear unit	see <b>page 16</b>	see <b>page 16</b>
Motor	BG75X75PI	1FK7034-2AK71-1UH0
Adapter	ZBE-375575	ZBE-375543

For more information regarding motors and motor adapters, please visit **page 5**

### Dimensional drawing

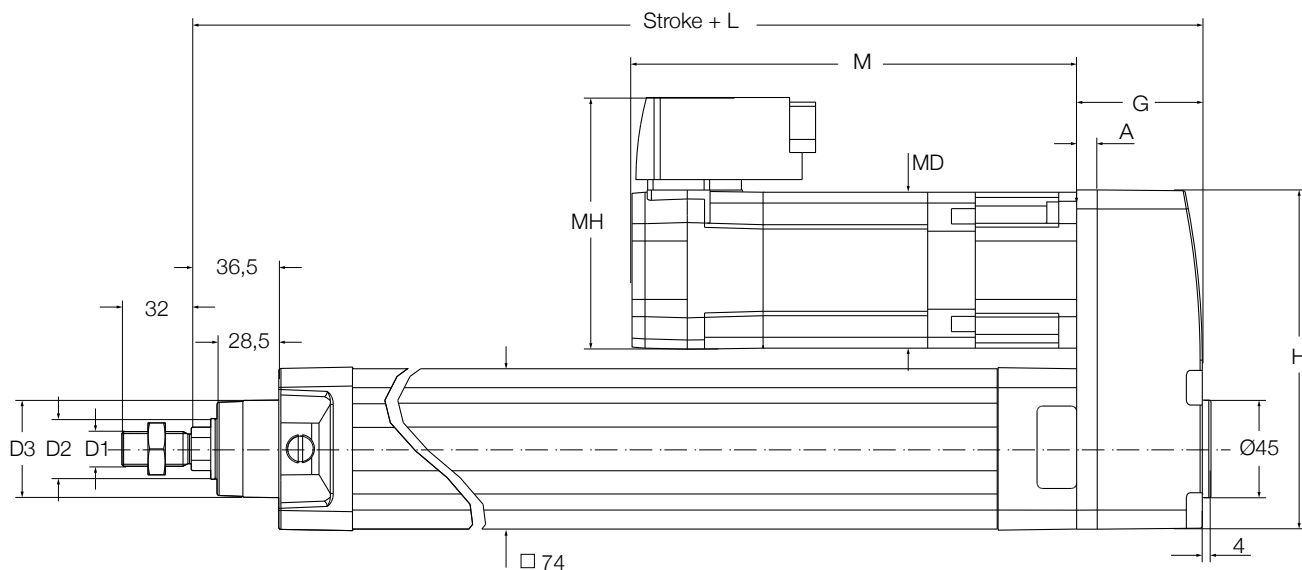

Motor	D1	D2	D3	L	G	A	H	M	MD	MH
BG75	M16 × 1,5	Ø28	Ø45	281,1	39,5	9	157,3	234	75	100
1FK7034	M16 × 1,5	Ø28	Ø45	272,1	58,1	9	157,3	200	72	117

### Performance diagrams

Axial force [N]

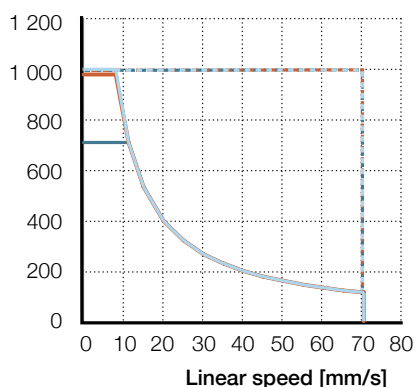

Radial load [N]

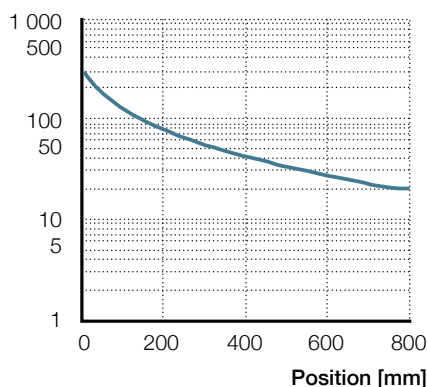

F<sub>m</sub> [N]

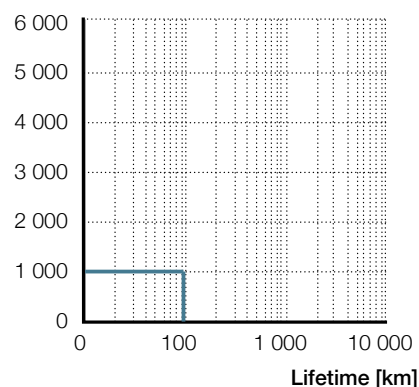

BG75	1FK7034	1FK7034
— F <sub>cont</sub>	— F <sub>cont</sub>	— F <sub>cont</sub>
- - - F <sub>peak</sub>	- - - F <sub>peak</sub>	- - - F <sub>peak</sub>

— CASM-63-LS
--------------

— CASM-63-LS
--------------

### Ordering key

See page 60

# CASM-63-BS

Electric cylinder motor,  
inline configuration



## Technical data

Designation	Symbol	Unit	BLDC motor BG75	Servo motor 1FK7034	Servo motor 1FK7044
<b>Performance Data</b>					
Continuous force @ zero speed	$F_{c0}$	kN	1,226	1,707	4,797
Continuous force @ max. speed	$F_c$	kN	1,226	1,479	3,65
Peak force @ zero speed	$F_{p0}$	kN	4,02	5,4	5,4
Peak force @ max. speed	$F_p$	kN	1,43	5,4	5,4
Dynamic load capacity	C	kN	13,7	13,7	13,7
Holding force (motorbrake option)	$F_{Hold}$	kN	1,26	2,4	5,15
Max. linear speed	$v_{max}$	mm/s	300	300	300
Max. acceleration	$a_{max}$	m/s <sup>2</sup>	5	5	5
Duty cycle	D	%	100	100	100
<b>Mechanical Data</b>					
Screw type	–	–	Ball screw	Ball screw	Ball screw
Screw diameter	$d_{screw}$	mm	20	20	20
Screw lead	$p_{screw}$	mm	5	5	5
Lead accuracy	–	–	G7	G7	G7
Stroke	s	mm	100...800	100...800	100...800
Internal overstroke each side	$s_0$	mm	1	1	1
Backlash	$s_{backlash}$	mm	0,07	0,07	0,07
Gear reduction	i	–	1	1	1
Efficiency	$\eta$	%	77	75	77
Inertia @ 0 mm stroke	J	10 <sup>-4</sup> kgm <sup>2</sup>	1,612	1,86	2,22
$\Delta$ Inertia per 100 mm stroke	$\Delta J$	10 <sup>-4</sup> kgm <sup>2</sup>	0,0809	0,0809	0,0809
Inertia of optional brake	$J_{brake}$	10 <sup>-4</sup> kgm <sup>2</sup>	0	0,1	0,36
Weight @ 0 mm stroke	m	kg	6,05	6,75	10,65
$\Delta$ weight per 100 mm stroke	$\Delta m$	kg	0,81	0,81	0,81
Weight of optional brake	$m_{brake}$	kg	0,5	0,4	0,6
<b>Electrical Data</b>					
Motor type	–	–	Brushless DC	Servo	Servo
Nominal voltage	U	V DC	40	N/A	N/A
Nominal current	I	A	12,7	1,3	3,9
Peak current	$I_{peak}$	A	50	1,9	5,4
Nominal power	P	kW	0,45	0,6	1,4
<b>Environment and Standards</b>					
Ambient temperature	$T_{ambient}$	°C	0...+50	0...+50	0...+50
Degree of protection	IP	–	54S	54S	54S
Standards	–	–	ISO 15552	ISO 15552	ISO 15552

## Ordering information

	BG75	1FK7034	1FK7044
Linear unit	see <a href="#">page 16</a>	see <a href="#">page 16</a>	see <a href="#">page 16</a>
Motor	BG75X75PI	1FK7034-2AK71-1UH0	1FK7044-4CH71-1UH0
Adapter	ZBE-375572	ZBE-375544	ZBE-375535

For more information regarding motors and motor adapters, please visit [page 5](#).



### Dimensional drawing

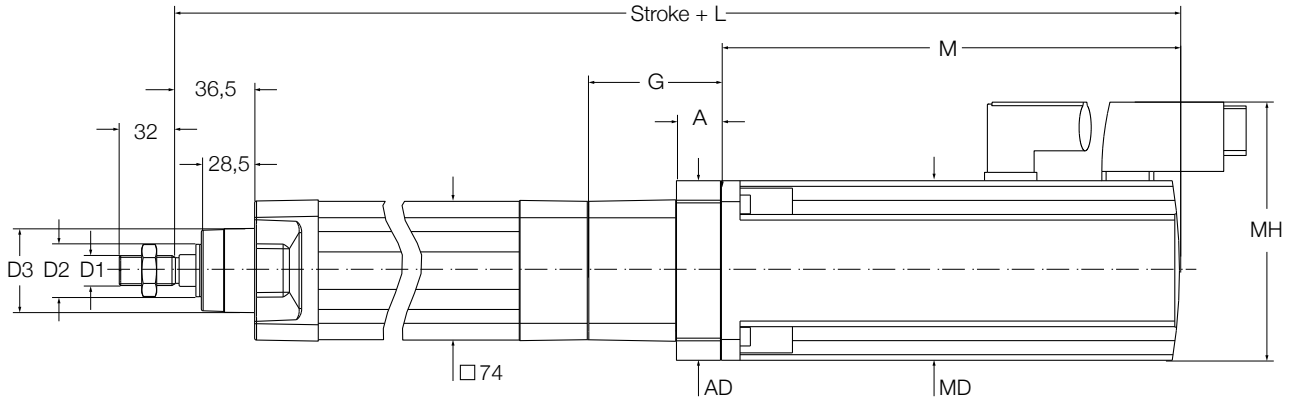

Motor	D1	D2	D3	L	G	A	AD	M	MD	MH
		mm								
BG75	M16 × 1,5	Ø28	Ø45	515,1	67,1	20	75	234	75	100
1FK7034	M16 × 1,5	Ø28	Ø45	476,4	62,4	15	75	200	72	117
1FK7044	M16 × 1,5	Ø28	Ø45	529,9	70,9	23,5	96	245	96	138

### Performance diagrams

Axial force [N]

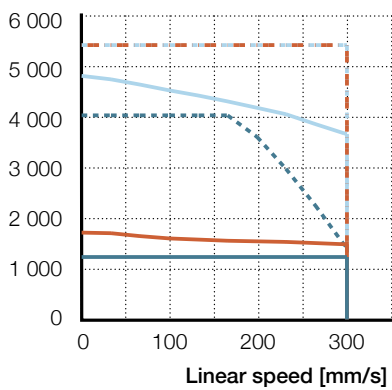

Radial load [N]

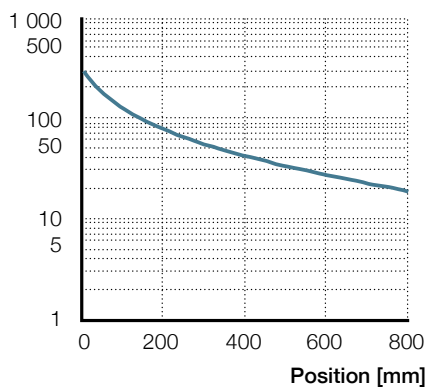

F<sub>m</sub> [N]

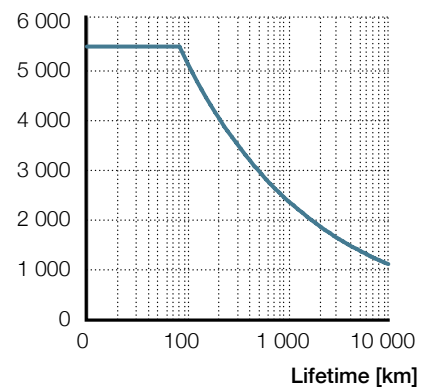

BG75	1FK7034	1FK7044
— F <sub>cont</sub>	— F <sub>cont</sub>	— F <sub>cont</sub>
- - - F <sub>peak</sub>	- - - F <sub>peak</sub>	- - - F <sub>peak</sub>

— CASM-63-BS
--------------

— CASM-63-BS
--------------

### Ordering key

See page 60

# CASM-63-BS

Electric cylinder motor,  
parallel configuration



## Technical data

Designation	Symbol	Unit	BLDC motor BG75	Servo motor 1FK7034
<b>Performance Data</b>				
Continuous force @ zero speed	$F_{c0}$	kN	1,226	1,707
Continuous force @ max. speed	$F_c$	kN	1,226	1,479
Peak force @ zero speed	$F_{p0}$	kN	4,02	5,4
Peak force @ max. speed	$F_p$	kN	1,43	5,4
Dynamic load capacity	$C$	kN	13,7	13,7
Holding force (motorbrake option)	$F_{Hold}$	kN	1,26	2,4
Max. linear speed	$v_{max}$	mm/s	300	300
Max. acceleration	$a_{max}$	m/s <sup>2</sup>	5	5
Duty cycle	$D$	%	100	100
<b>Mechanical Data</b>				
Screw type	–	–	Ball screw	Ball screw
Screw diameter	$d_{screw}$	mm	20	20
Screw lead	$p_{screw}$	mm	5	5
Lead accuracy	–	–	G7	G7
Stroke	$s$	mm	100...800	100...800
Internal overstroke each side	$s_0$	mm	1	1
Backlash	$s_{backlash}$	mm	0,07	0,07
Gear reduction	$i$	–	1	1
Efficiency	$\eta$	%	76	74
Inertia @ 0 mm stroke	$J$	10 <sup>-4</sup> kgm <sup>2</sup>	1,4668	1,7148
Δ Inertia per 100 mm stroke	$\Delta J$	10 <sup>-4</sup> kgm <sup>2</sup>	0,0809	0,0809
Inertia of optional brake	$J_{brake}$	10 <sup>-4</sup> kgm <sup>2</sup>	0	0,1
Weight @ 0 mm stroke	$m$	kg	6,15	6,85
Δ weight per 100 mm stroke	$\Delta m$	kg	0,81	0,81
Weight of optional brake	$m_{brake}$	kg	0,5	0,4
<b>Electrical Data</b>				
Motor type	–	–	Brushless DC	Servo
Nominal voltage	$U$	V DC	40	N/A
Nominal current	$I$	A	12,7	1,3
Peak current	$I_{peak}$	A	50	1,9
Nominal power	$P$	kW	0,45	0,6
<b>Environment and Standards</b>				
Ambient temperature	$T_{ambient}$	°C	0...+50	0...+50
Degree of protection	IP	–	54S	54S
Standards	–	–	ISO 15552	ISO 15552

## Ordering information

	BG75	1FK7034
Linear unit	see <b>page 16</b>	see <b>page 16</b>
Motor	BG75X75PI	1FK7034-2AK71-1UH0
Adapter	ZBE-375575	ZBE-375543

For more information regarding motors and motor adapters, please visit **page 5**.

### Dimensional drawing

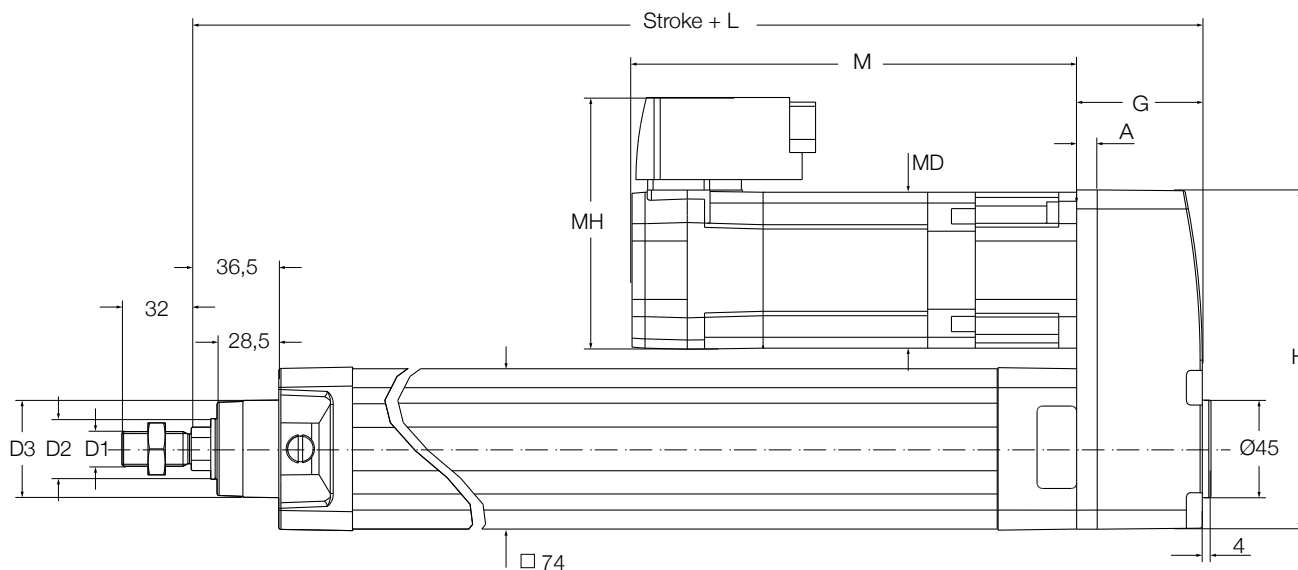

Motor	D1	D2	D3	L	G	A	H	M	MD	MH
BG75	M16 × 1,5	Ø28	Ø45	281,1	39,5	9	157,3	234	75	100
1FK7034	M16 × 1,5	Ø28	Ø45	272,1	58,1	9	157,3	200	72	117

### Performance diagrams

Axial force [N]

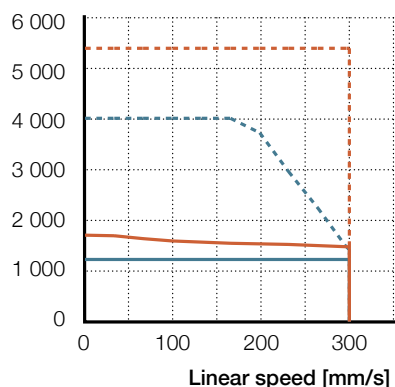

Radial load [N]

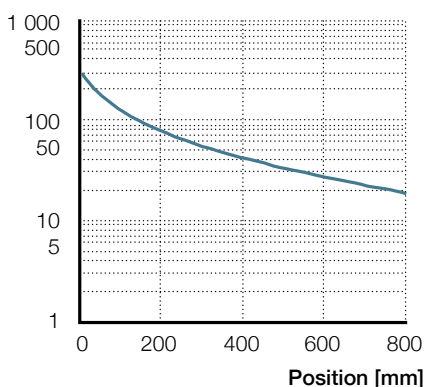

F<sub>m</sub> [N]

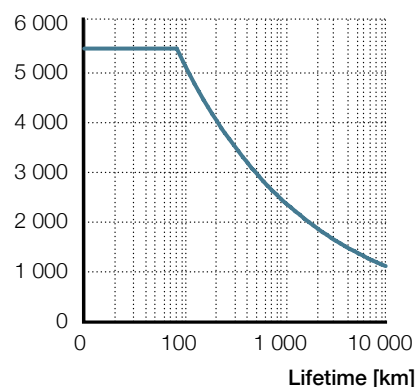

BG75      1FK7034  
 — F<sub>cont</sub>    - - - F<sub>peak</sub>    — F<sub>cont</sub>    - - - F<sub>peak</sub>

— CASM-63-BS

— CASM-63-BS

### Ordering key

See page 60

# CASM-63-BN

Electric cylinder motor,  
inline configuration



## Technical data

Designation	Symbol	Unit	BLDC motor BG75	Servo motor 1FK7034	Servo motor 1FK7044
<b>Performance Data</b>					
Continuous force @ zero speed	$F_{c0}$	kN	0,620	0,855	2,403
Continuous force @ max. speed	$F_c$	kN	0,620	0,769	1,933
Peak force @ zero speed	$F_{p0}$	kN	2,190	3,471	5,400
Peak force @ max. speed	$F_p$	kN	1,081	3,471	5,400
Dynamic load capacity	$C$	kN	21	21	21
Holding force (motorbrake option)	$F_{Hold}$	kN	0,739	1,404	2,956
Max. linear speed	$v_{max}$	mm/s	533	533	533
Max. acceleration	$a_{max}$	m/s <sup>2</sup>	6	6	6
Duty cycle	$D$	%	100	100	100
<b>Mechanical Data</b>					
Screw type	–	–	Ball screw	Ball screw	Ball screw
Screw diameter	$d_{screw}$	mm	20	20	20
Screw lead	$p_{screw}$	mm	10	10	10
Lead accuracy	–	–	G7	G7	G7
Stroke	$s$	mm	100...800	100...800	100...800
Internal overstroke each side	$s_0$	mm	1	1	1
Backlash	$s_{backlash}$	mm	0,07	0,07	0,07
Gear reduction	$i$	–	1	1	1
Efficiency	$\eta$	%	77	75	77
Inertia @ 0 mm stroke	$J$	10 <sup>-4</sup> kgm <sup>2</sup>	1,6120	1,8600	2,2200
Δ Inertia per 100 mm stroke	$\Delta J$	10 <sup>-4</sup> kgm <sup>2</sup>	0,0809	0,0809	0,0809
Inertia of optional brake	$J_{brake}$	10 <sup>-4</sup> kgm <sup>2</sup>	0,0000	0,1000	0,3600
Weight @ 0 mm stroke	$m$	kg	6,05	6,75	10,65
Δ weight per 100 mm stroke	$\Delta m$	kg	0,81	0,81	0,81
Weight of optional brake	$m_{brake}$	kg	0,50	0,40	0,60
<b>Electrical Data</b>					
Motor type	–	–	Brushless DC	Servo	Servo
Nominal voltage	$U$	V DC	40	N/A	N/A
Nominal current	$I$	A	12,7	1,3	3,9
Peak current	$I_{peak}$	A	50,0	1,9	5,4
Nominal power	$P$	kW	0,450	0,600	1,400
<b>Environment and Standards</b>					
Ambient temperature	$T_{ambient}$	°C	0...+50	0...+50	0...+50
Degree of protection	IP	–	54S	54S	54S
Standards	–	–	ISO 15552	ISO 15552	ISO 15552

## Ordering information

	BG75	1FK7034	1FK7044
Linear unit	see page 16	see page 16	see page 16
Motor	BG75X75PI	1FK7034-2AK71-1UH0	1FK7044-4CH71-1UH0
Adapter	ZBE-375572	ZBE-375544	ZBE-375535

For more information regarding motors and motor adapters, please visit [page 5](#)

### Dimensional drawing

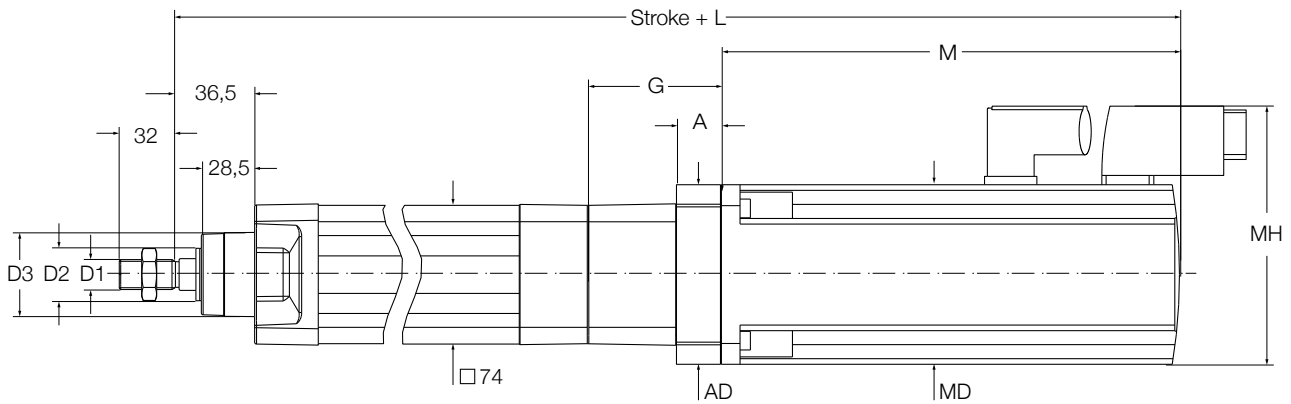

Motor	D1	D2 mm	D3	L	G	A	AD	M	MD	MH
BG75	M16 × 1,5	Ø28	Ø45	515,1	67,1	20	75	234	75	100
1FK7034	M16 × 1,5	Ø28	Ø45	476,4	62,4	15	75	200	72	117
1FK7044	M16 × 1,5	Ø28	Ø45	529,9	70,9	23,5	96	245	96	138

### Performance diagrams

Axial force [N]

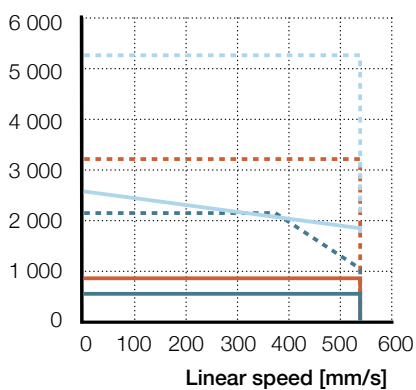

Radial load [N]

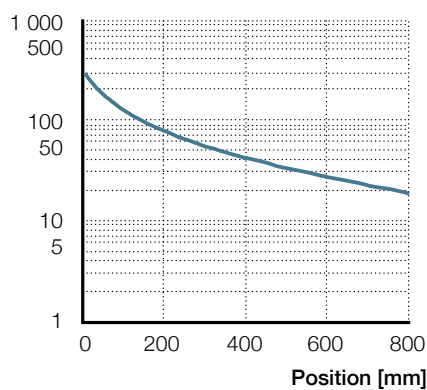

F<sub>m</sub> [N]

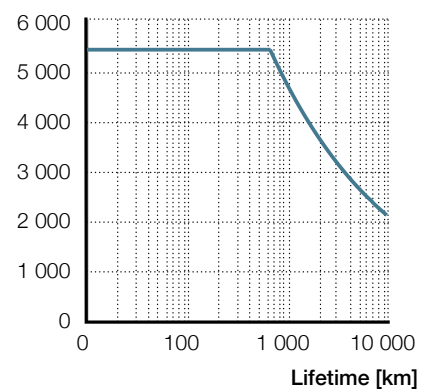

BG75	1FK7034	1FK7044
— F <sub>cont</sub>	— F <sub>cont</sub>	— F <sub>cont</sub>
- - - F <sub>peak</sub>	- - - F <sub>peak</sub>	- - - F <sub>peak</sub>

— CASM-63-BN
--------------

— CASM-63-BN
--------------

### Ordering key

See page 60

# CASM-63-BN

Electric cylinder motor,  
parallel configuration



## Technical data

Designation	Symbol	Unit	BLDC motor BG75	Servo motor 1FK7034
<b>Performance Data</b>				
Continuous force @ zero speed	$F_{c0}$	kN	0,613	0,846
Continuous force @ max. speed	$F_c$	kN	0,613	0,761
Peak force @ zero speed	$F_{p0}$	kN	2,168	2,937
Peak force @ max. speed	$F_p$	kN	1,070	2,937
Dynamic load capacity	$C$	kN	21	21
Holding force (motorbrake option)	$F_{Hold}$	kN	0,739	1,404
Max. linear speed	$v_{max}$	mm/s	533	533
Max. acceleration	$a_{max}$	m/s <sup>2</sup>	6	6
Duty cycle	$D$	%	100	100
<b>Mechanical Data</b>				
Screw type	–	–	Ball screw	Ball screw
Screw diameter	$d_{screw}$	mm	20	20
Screw lead	$p_{screw}$	mm	10	10
Lead accuracy	–	–	G7	G7
Stroke	$s$	mm	100...800	100...800
Internal overstroke each side	$s_0$	mm	1	1
Backlash	$s_{backlash}$	mm	0,07	0,07
Gear reduction	$i$	–	1	1
Efficiency	$\eta$	%	76	74
Inertia @ 0 mm stroke	$J$	10 <sup>-4</sup> kgm <sup>2</sup>	1,4668	1,7148
Δ Inertia per 100 mm stroke	$\Delta J$	10 <sup>-4</sup> kgm <sup>2</sup>	0,0809	0,0809
Inertia of optional brake	$J_{brake}$	10 <sup>-4</sup> kgm <sup>2</sup>	0,0000	0,1000
Weight @ 0 mm stroke	$m$	kg	6,15	6,85
Δ weight per 100 mm stroke	$\Delta m$	kg	0,81	0,81
Weight of optional brake	$m_{brake}$	kg	0,50	0,40
<b>Electrical Data</b>				
Motor type	–	–	Brushless DC	Servo
Nominal voltage	$U$	V DC	40	N/A
Nominal current	$I$	A	12,7	1,3
Peak current	$I_{peak}$	A	50	1,9
Nominal power	$P$	kW	0,450	0,600
<b>Environment and Standards</b>				
Ambient temperature	$T_{ambient}$	°C	0...+50	0...+50
Degree of protection	IP	–	54S	54S
Standards	–	–	ISO 15552	ISO 15552

## Ordering information

	BG75	1FK7034
Linear unit	see <b>page 16</b>	see <b>page 16</b>
Motor	BG75X75PI	1FK7034-2AK71-1UH0
Adapter	ZBE-375575	ZBE-375543

For more information regarding motors and motor adapters, please visit **page 5**

### Dimensional drawing

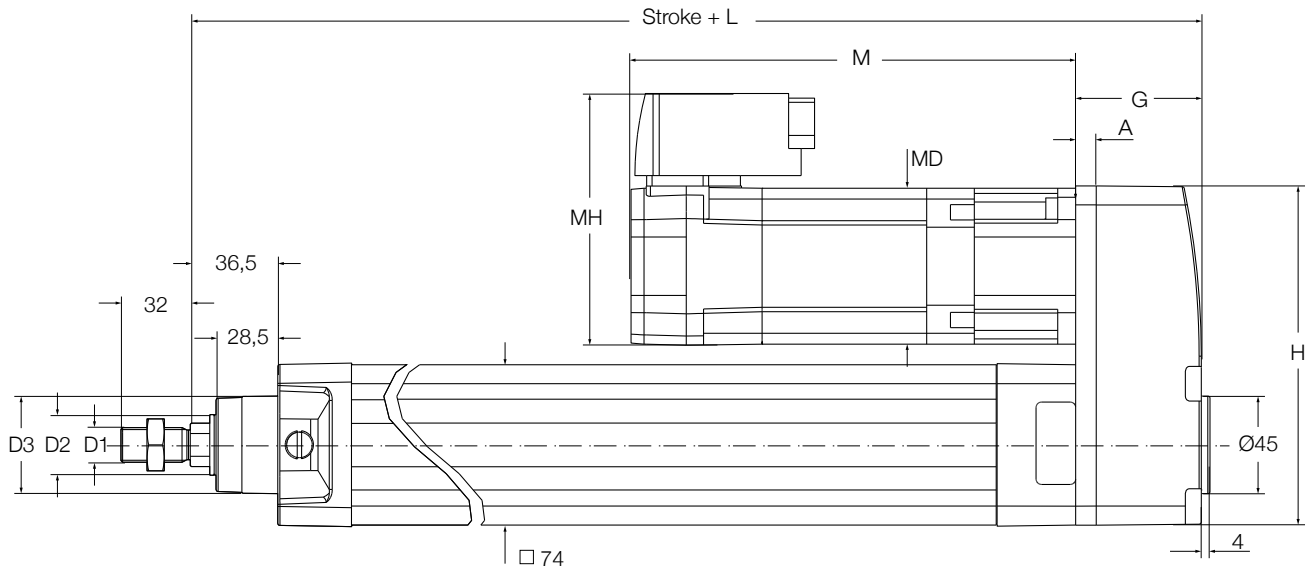

Motor	D1	D2	D3	L	G	A	H	M	MD	MH
BG75	M16 × 1,5	Ø28	Ø45	281,1	39,5	9	157,3	234	75	100
1FK7034	M16 × 1,5	Ø28	Ø45	272,1	58,1	9	157,3	200	72	117

### Performance diagrams

Axial force [N]

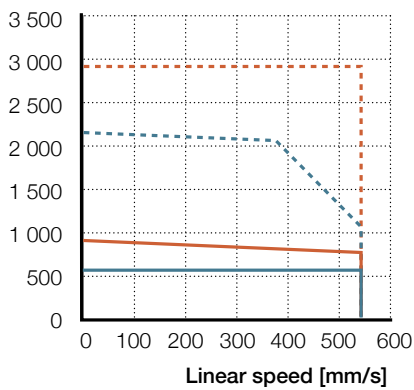

BG75      1FK7034  
 — F<sub>cont</sub>    - - - F<sub>peak</sub>    — F<sub>cont</sub>    - - - F<sub>peak</sub>

Radial load [N]

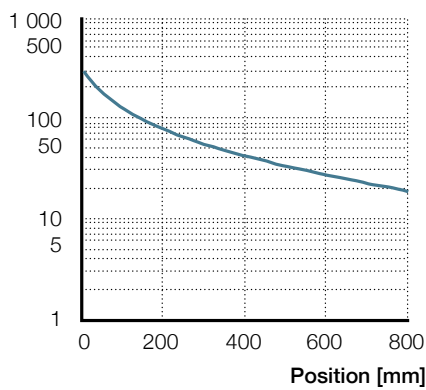

— CASM-63-BN

F<sub>m</sub> [N]

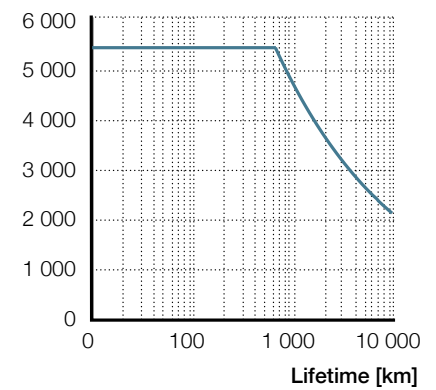

— CASM-63-BN

### Ordering key

See page 60

# CASM-63-BF

Electric cylinder motor,  
inline configuration



## Technical data

Designation	Symbol	Unit	BLDC motor BG75	Servo motor 1FK7034	Servo motor 1FK7044
<b>Performance Data</b>					
Continuous force @ zero speed	$F_{c0}$	kN	0,313	0,432	1,216
Continuous force @ max. speed	$F_c$	kN	0,313	0,389	0,978
Peak force @ zero speed	$F_{p0}$	kN	1,108	1,756	2,800
Peak force @ max. speed	$F_p$	kN	0,547	1,756	2,800
Dynamic load capacity	$C$	kN	10	10	10
Holding force (motorbrake option)	$F_{Hold}$	kN	0,365	0,694	1,461
Max. linear speed	$v_{max}$	mm/s	1 067	1 067	1 067
Max. acceleration	$a_{max}$	m/s <sup>2</sup>	6	6	6
Duty cycle	$D$	%	100	100	100
<b>Mechanical Data</b>					
Screw type	–	–	Ball screw	Ball screw	Ball screw
Screw diameter	$d_{screw}$	mm	20	20	20
Screw lead	$p_{screw}$	mm	20	20	20
Lead accuracy	–	–	G7	G7	G7
Stroke	$s$	mm	100...800	100...800	100...800
Internal overstroke each side	$s_0$	mm	1	1	1
Backlash	$s_{backlash}$	mm	0,07	0,07	0,07
Gear reduction	$i$	–	1	1	1
Efficiency	$\eta$	%	77	76	78
Inertia @ 0 mm stroke	$J$	10 <sup>-4</sup> kgm <sup>2</sup>	1,6156	1,8636	2,2236
Δ Inertia per 100 mm stroke	$\Delta J$	10 <sup>-4</sup> kgm <sup>2</sup>	0,0855	0,0855	0,0855
Inertia of optional brake	$J_{brake}$	10 <sup>-4</sup> kgm <sup>2</sup>	0	0,1000	0,3600
Weight @ 0 mm stroke	$m$	kg	6,05	6,75	10,65
Δ weight per 100 mm stroke	$\Delta m$	kg	0,81	0,81	0,81
Weight of optional brake	$m_{brake}$	kg	0,50	0,40	0,60
<b>Electrical Data</b>					
Motor type	–	–	Brushless DC	Servo	Servo
Nominal voltage	$U$	V DC	40	N/A	N/A
Nominal current	$I$	A	12,7	1,3	3,9
Peak current	$I_{peak}$	A	50,0	1,9	5,4
Nominal power	$P$	kW	0,450	0,600	1,400
<b>Environment and Standards</b>					
Ambient temperature	$T_{ambient}$	°C	0...+50	0...+50	0...+50
Degree of protection	IP	–	54S	54S	54S
Standards	–	–	ISO 15552	ISO 15552	ISO 15552

## Ordering information

	BG75	1FK7034	1FK7044
Linear unit	see <b>page 16</b>	see <b>page 16</b>	see <b>page 16</b>
Motor	BG75X75PI	1FK7034-2AK71-1UH0	1FK7044-4CH71-1UH0
Adapter	ZBE-375572	ZBE-375544	ZBE-375535

For more information regarding motors and motor adapters, please visit **page 5**



### Dimensional drawing

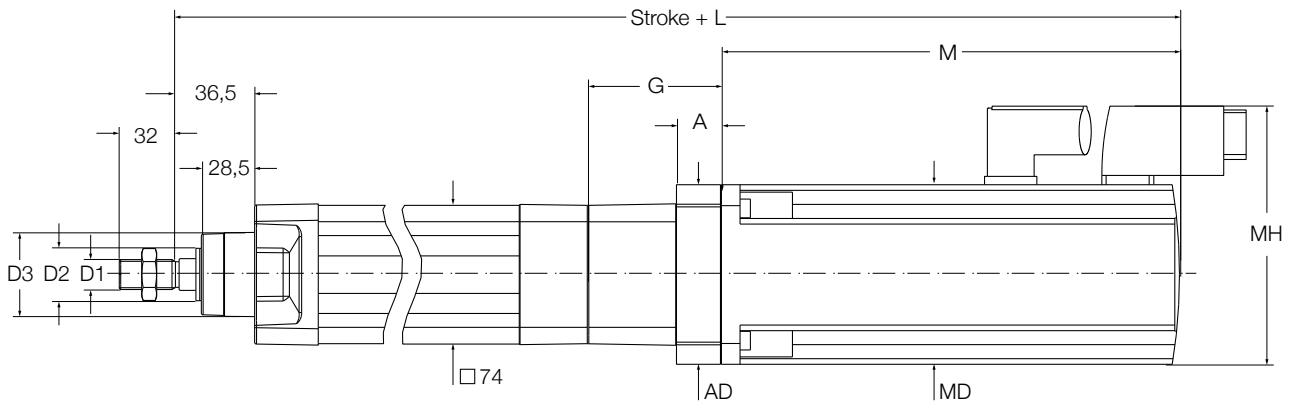

Motor	D1	D2 mm	D3	L	G	A	AD	M	MD	MH
BG75	M16 × 1,5	Ø28	Ø45	515,1	67,1	20	75	234	75	100
1FK7034	M16 × 1,5	Ø28	Ø45	476,4	62,4	15	75	200	72	117
1FK7044	M16 × 1,5	Ø28	Ø45	529,9	70,9	23,5	96	245	96	138

### Performance diagrams

Axial force [N]

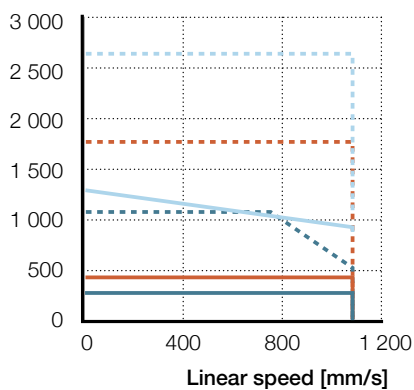

Radial load [N]

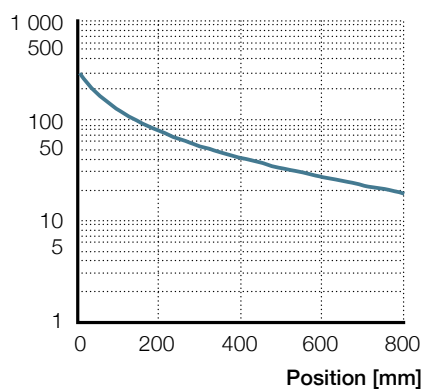

F<sub>m</sub> [N]

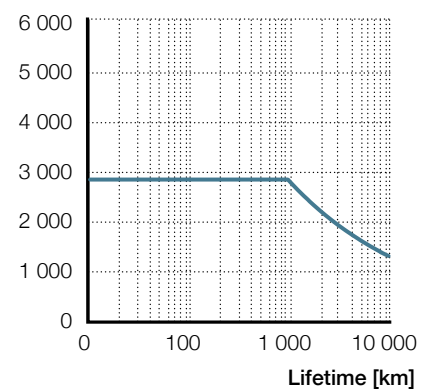

BG75	1FK7034	1FK7044
— F <sub>cont</sub>	— F <sub>cont</sub>	— F <sub>cont</sub>
- - - F <sub>peak</sub>	- - - F <sub>peak</sub>	- - - F <sub>peak</sub>

— CASM-63-BF
--------------

— CASM-63-BF
--------------

### Ordering key

See page 60

# CASM-63-BF

Electric cylinder motor,  
parallel configuration



## Technical data

Designation	Symbol	Unit	BLDC motor BG75	Servo motor 1FK7034
<b>Performance Data</b>				
Continuous force @ zero speed	$F_{c0}$	kN	0,310	0,428
Continuous force @ max. speed	$F_c$	kN	0,310	0,385
Peak force @ zero speed	$F_{p0}$	kN	1,097	1,486
Peak force @ max. speed	$F_p$	kN	0,541	1,486
Dynamic load capacity	$C$	kN	10	10
Holding force (motorbrake option)	$F_{Hold}$	kN	0,365	0,694
Max. linear speed	$v_{max}$	mm/s	1 067	1 067
Max. acceleration	$a_{max}$	m/s <sup>2</sup>	6	6
Duty cycle	$D$	%	100	100
<b>Mechanical Data</b>				
Screw type	–	–	Ball screw	Ball screw
Screw diameter	$d_{screw}$	mm	20	20
Screw lead	$p_{screw}$	mm	20	20
Lead accuracy	–	–	G7	G7
Stroke	$s$	mm	100...800	100...800
Internal overstroke each side	$s_0$	mm	1	1
Backlash	$s_{backlash}$	mm	0,07	0,07
Gear reduction	$i$	–	1	1
Efficiency	$\eta$	%	77	75
Inertia @ 0 mm stroke	$J$	10 <sup>-4</sup> kgm <sup>2</sup>	1,4704	1,7184
Δ Inertia per 100 mm stroke	$\Delta J$	10 <sup>-4</sup> kgm <sup>2</sup>	0,0855	0,0855
Inertia of optional brake	$J_{brake}$	10 <sup>-4</sup> kgm <sup>2</sup>	0,0000	0,1000
Weight @ 0 mm stroke	$m$	kg	6,15	6,85
Δ weight per 100 mm stroke	$\Delta m$	kg	0,81	0,81
Weight of optional brake	$m_{brake}$	kg	0,50	0,40
<b>Electrical Data</b>				
Motor type	–	–	Brushless DC	Servo
Nominal voltage	$U$	V DC	40	N/A
Nominal current	$I$	A	12,7	1,3
Peak current	$I_{peak}$	A	50,0	1,9
Nominal power	$P$	kW	0,450	0,600
<b>Environment and Standards</b>				
Ambient temperature	$T_{ambient}$	°C	0...+50	0...+50
Degree of protection	IP	–	54S	54S
Standards	–	–	ISO 15552	ISO 15552

## Ordering information

	BG75	1FK7034
Linear unit	see <b>page 16</b>	see <b>page 16</b>
Motor	BG75X75PI	1FK7034-2AK71-1UH0
Adapter	ZBE-375575	ZBE-375543

For more information regarding motors and motor adapters, please visit **page 5**

### Dimensional drawing

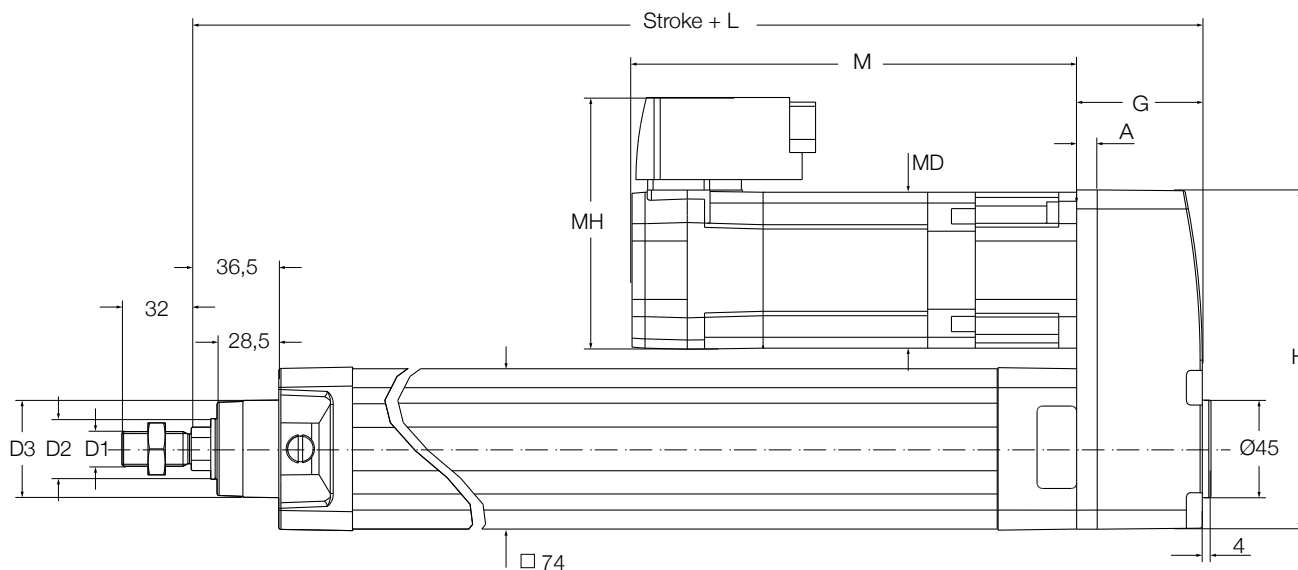

Motor	D1	D2	D3	L	G	A	H	M	MD	MH
BG75	M16 × 1,5	Ø28	Ø45	281,1	58,1	9	157,3	234	75	100
1FK7034	M16 × 1,5	Ø28	Ø45	272,1	58,1	9	157,3	200	72	117

### Performance diagrams

Axial force [N]

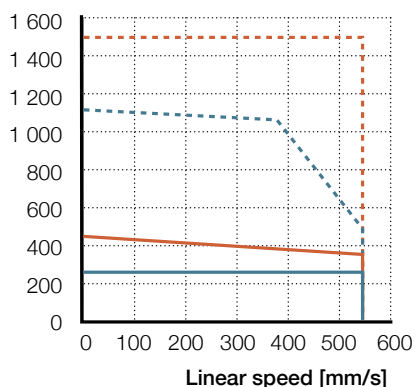

Radial load [N]

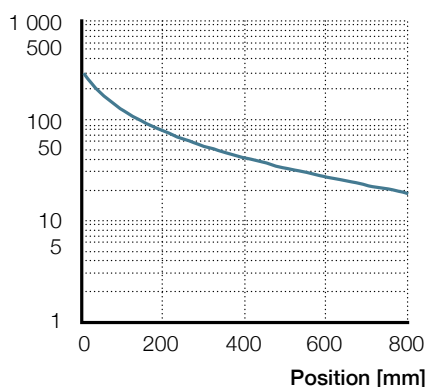

F<sub>m</sub> [N]

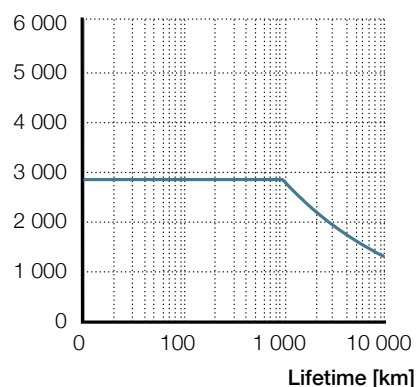

BG75 1FK7034

— F<sub>cont</sub> — F<sub>cont</sub>  
 - - - F<sub>peak</sub> - - - F<sub>peak</sub>

— CASM-63-BF

— CASM-63-BF

### Ordering key

See page 60

## Ordering key

### Linear units

C A S M - 3 2 - B S - 0 3 0 0 A M - 0 0 0

**Screw**

- LS Lead screw 9 × 1,5 mm
- BS Ball screw 10 × 3 mm
- BN Ball screw 10 × 10 mm

**Stroke**

- 50 mm
- 100 mm
- 150 mm
- 200 mm
- 300 mm
- 400 mm

**Option<sup>1)</sup>**

- A Motor, adapter and accessories separately delivered
- M Motor, adapter and foot mountings<sup>2)</sup> pre-mounted

**Customer option**

- 000 No option

C A S M - 4 0 - L S - 0 1 0 0 A A - 0 0 0

**Screw**

- LS Lead screw 12,5 × 2,5 mm
- BS Ball screw 12 × 5 mm
- BN Ball screw 12,7 × 12,7 mm

**Stroke**

- 100 mm
- 200 mm
- 300 mm
- 400 mm
- 500 mm
- 600 mm

**Option<sup>1)</sup>**

- A Motor, adapter and accessories separately delivered
- M Motor, adapter and foot mountings<sup>2)</sup> pre-mounted

**Customer option**

- 000 No option

C A S M - 6 3 - B F - 0 7 0 0 A A - 0 0 0

**Screw**

- LS Lead screw 20 × 4 mm
- BS Ball screw 20 × 5 mm
- BN Ball screw 20 × 10 mm
- BF Ball screw 20 × 20 mm

**Stroke**

- 100 mm
- 200 mm
- 300 mm
- 400 mm
- 500 mm
- 600 mm
- 700 mm
- 800 mm

**Option<sup>1)</sup>**

- A Motor, adapter and accessories separately delivered
- M Motor, adapter and foot mountings<sup>2)</sup> pre-mounted

**Customer option**

- 000 No option

<sup>1)</sup> Motor, adapter kit and accessories need to be ordered separately

<sup>2)</sup> Foot mountings pre-mounted on inline version only

## Servo motors

Motor
1FK7015-5AK71-1SH3
1FK7022-5AK71-1UH3
1FK7034-2AK71-1UH0
1FK7044-4CH71-1UH0

## Brushless DC motors

Motor
BG45x30PI
BG65Sx50PI
BG75x75PI

## Brushless DC motors options

Motor options		
Brushless DC motor programming kit	–	ZBE-530615
Brushless DC motor cable 3 m	BG45x30PI	ZBE-530632-03
Brushless DC motor cable 10 m	BG45x30PI	ZBE-530632-10
Brushless DC motor cable 3 m	BG65Sx50PI	ZBE-530634-03
Brushless DC motor cable 10 m	BG65Sx50PI	ZBE-530643-10
Brushless DC motor cable 3 m	BG75x75PI	ZBE-530630-03
Brushless DC motor cable 10 m	BG75x75PI	ZBE-530630-10

## Adapters for Servo motors

Motor	CASM-32		CASM-40		CASM-63	
	Inline adapter	Parallel adapter	Inline adapter	Parallel adapter	Inline adapter	Parallel adapter
1FK7015-5AK-71-1SH3	ZBE-375530	ZBE-375540	–	–	–	–
1FK7022-5AK71-1UH3	ZBE-375537	–	ZBE-375538	ZBE-375546	–	–
1FK7034-2AK71-1UH0	–	–	ZBE-375545	ZBE-375603	ZBE-375544	ZBE-375543
1FK7044-4CH71-1UH0	–	–	–	–	ZBE-375535	–

## Adapters for brushless DC motors

Motor	CASM-32		CASM-40		CASM-63	
	Inline adapter	Parallel adapter	Inline adapter	Parallel adapter	Inline adapter	Parallel adapter
BG45x30PI	ZBE-375570	ZBE-375573	–	–	–	–
BG65Sx50PI	–	–	ZBE-375571	ZBE-375574	–	–
BG75x75PI	–	–	ZBE-375579	ZBE-375578	ZBE-375572	ZBE-375575

### Example

To order a CASM-32 with BG45 motor and parallel adapter the ordering key is the following:

CASM-32-BN-0150AM-000      BG45x30PI      ZBE-375573

## Replacement belt

Linear unit	Paralell interface	Replacemet belt
CASM-32	ZBE-375540	ZBE-375600-32
	ZBE-375573	ZBE-375600-32
	M/0130493	ZBE-375600-32
CASM-40	ZBE-375546	ZBE-375600-40
	ZBE-375603	ZBE-375600-63
	ZBE-375574	ZBE-375600-40
	ZBE-375578	ZBE-375600-63
	M/0130494	ZBE-375600-40
	M/0130647	ZBE-375600-63
CASM-63	ZBE-375543	ZBE-375600-63
	ZBE-375575	ZBE-375600-63
	M/0130495	ZBE-375600-63

# Accessories

## CASM-32

### Foot mounting kit\*



**Note:** The foot mounting between the linear unit and the adapter kit increases the length of the inline version by 4 mm

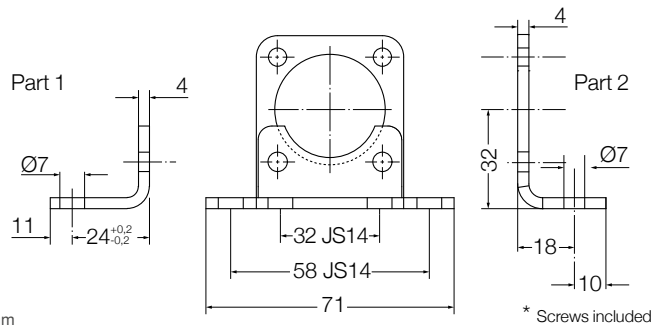

**Ordering key**  
ZBE-375501-32  
For parallel version (2x part 1)

**Ordering key**  
ZBE-375507-32  
For inline version (part 1 + part 2)

### Flange mounting kit\*

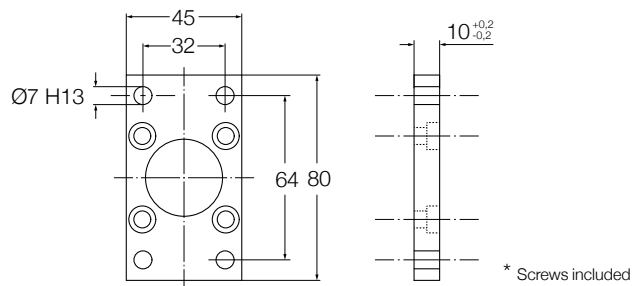

**Ordering key**  
ZBE-375502-32

### Trunnion flange kit\*

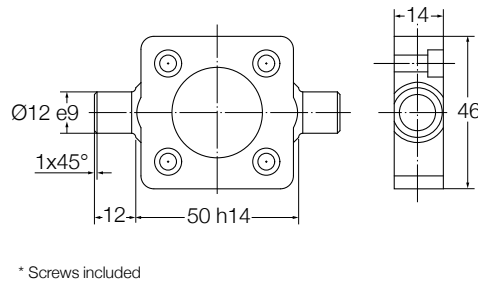

**Ordering key**  
ZBE-375503-32

### Trunnion mounting kit\*

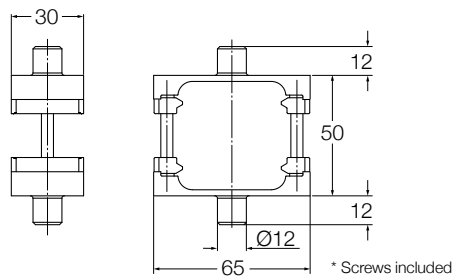

**Ordering key**  
ZBE-375508-32

### Trunnion support pair

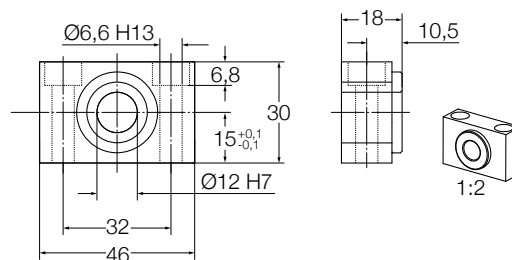

**Ordering key**  
ZBE-375509-32

**Note:** To be used with trunnion flange kit or trunnion mounting kit

**Swivel flange\***

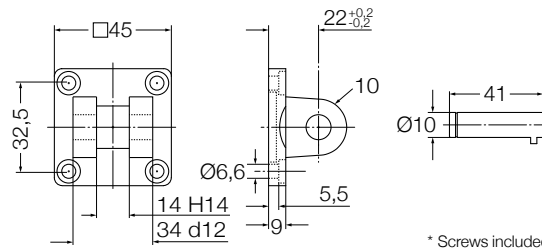

\* Screws included

**Ordering key**  
ZBE-375504-32  
For parallel version only

**Swivel flange with rod end\***

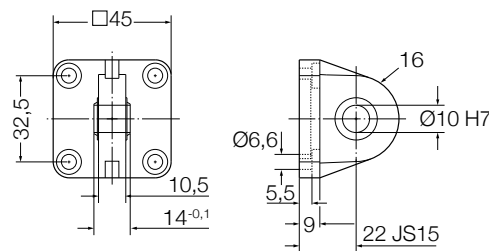

\* Screws included

**Ordering key**  
ZBE-375506-32  
For parallel version only

**Rod clevis**

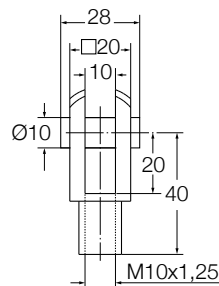

**Ordering key**  
ZBE-375510-32

**Rod end**

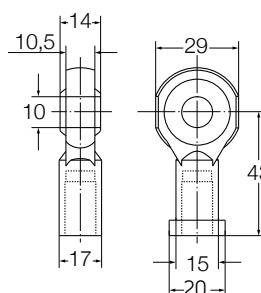

**Ordering key**  
ZBE-375511-32

**Proximity sensor**

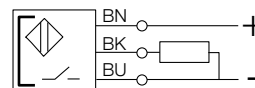
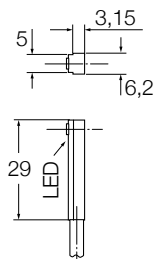

Switching function Normally open  
Output signal PNP  
Rated voltage 24 V DC  
Max. current 30 mA  
Cable length 5 m

**Ordering key**  
ZSC-375525-NO

**CASM-40**

**Foot mounting kit\***



**Note:** The foot mounting between the linear unit and the adapter kit increases the length of the inline version by 4 mm

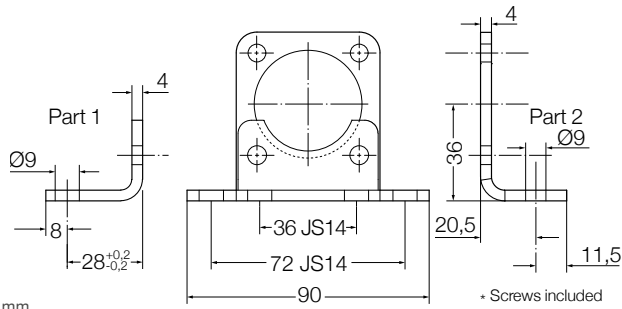

**Ordering key**

ZBE-375501-40  
For standard parallel adapter version  
ZBE-375501-40/63  
For bigger parallel adapter version  
(valid for ZBE-375603, ZBE-375578,  
M/0130647 or ZBE-375608 adapter  
references)

**Ordering key**

ZBE-375507-40  
For inline version (part 1 + part 2)

**Flange mounting kit\***

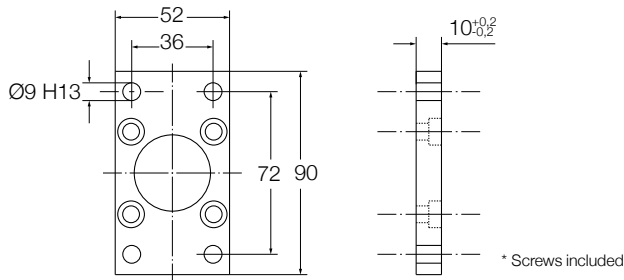

**Ordering key**

ZBE-375502-40

**Trunnion flange kit\***

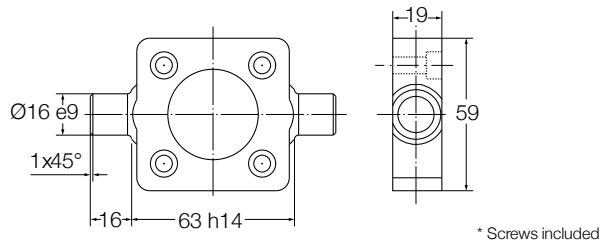

**Ordering key**

ZBE-375503-40

**Trunnion mounting kit\***

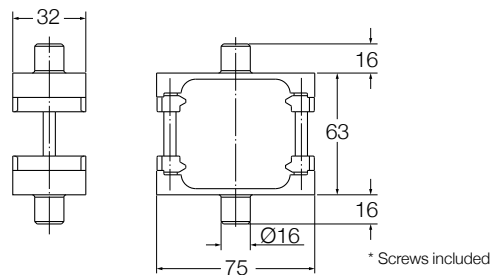

**Ordering key**

ZBE-375508-40

**Trunnion support pair**

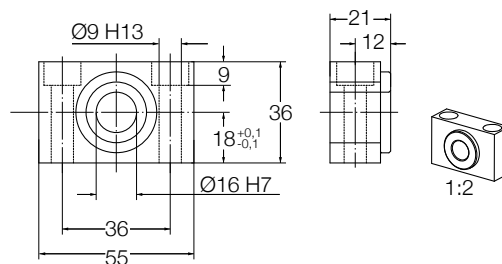

**Note:** To be used with trunnion flange kit or trunnion mounting kit

**Ordering key**

ZBE-375509-40



**Swivel flange\***

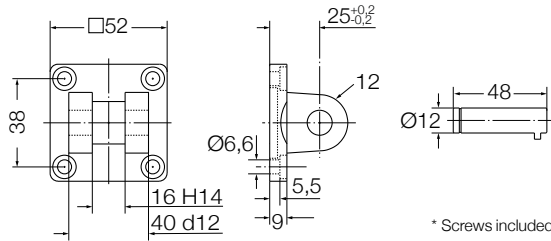

\* Screws included

**Ordering key**

ZBE-375504-40  
 For parallel version only. For parallel adapters ZBE-375603 and ZBE-375578 see CASM-63 equivalent accessories.

**Swivel flange with rod end\***

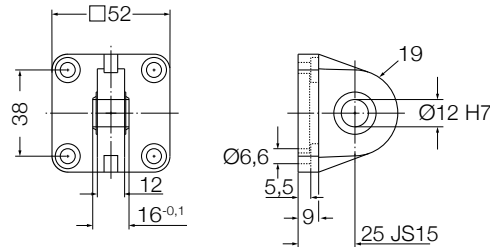

\* Screws included

**Ordering key**

ZBE-375506-40  
 For parallel version only. For parallel adapters ZBE-375603 and ZBE-375578 see CASM-63 equivalent accessories.

**Rod clevis**

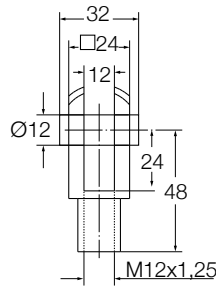

**Ordering key**

ZBE-375510-40

**Rod end**

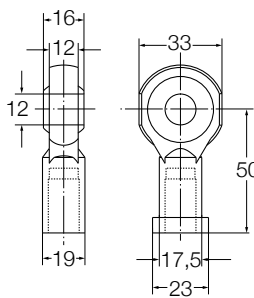

**Ordering key**

ZBE-375511-40

**Proximity sensor**

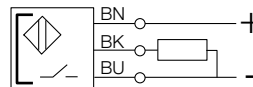
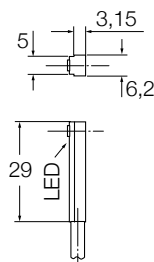

Switching function Normally open  
 Output signal PNP  
 Rated voltage 24 V DC  
 Max. current 30 mA  
 Cable length 5 m

**Ordering key**

ZSC-375525-NO

**CASM-63**

**Foot mounting kit\***



**Note:** The foot mounting between the linear unit and the adapter kit increases the length of the inline version by 5 mm

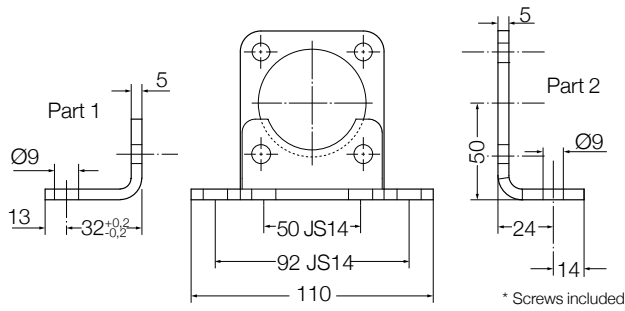

**Ordering key**  
ZBE-375501-63  
For parallel version with large adapter (dimensional information on request)

**Ordering key**  
ZBE-375507-63  
For inline version (part 1 + part 2)

**Flange mounting kit\***

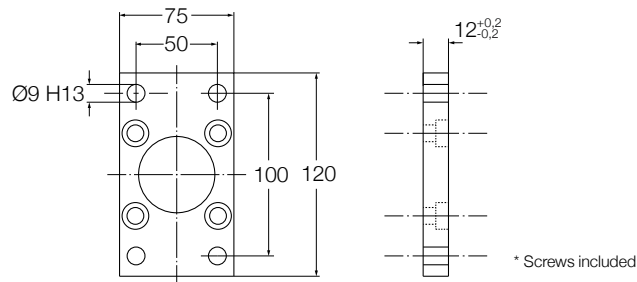

**Ordering key**  
ZBE-375502-63

**Trunnion flange kit\***

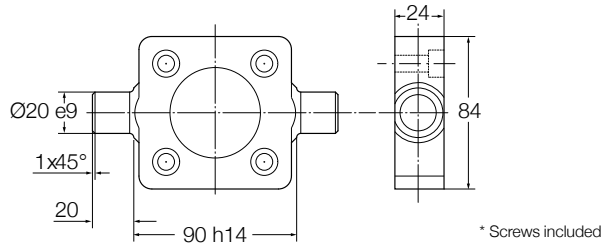

**Ordering key**  
ZBE-375503-63

**Trunnion mounting kit\***

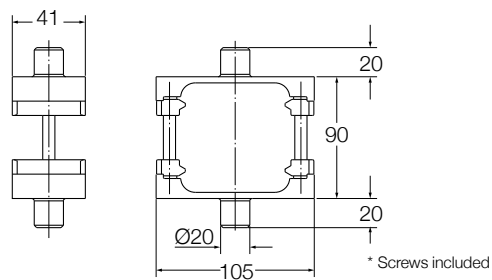

**Ordering key**  
ZBE-375508-63

**Trunnion support pair**

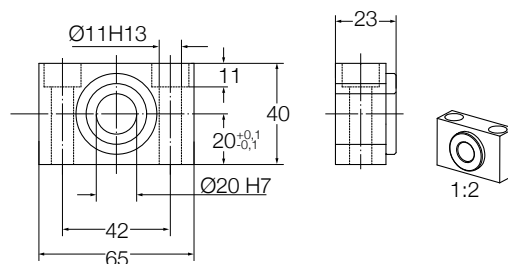

**Note:** To be used with trunnion flange kit or trunnion mounting kit

**Swivel flange\***

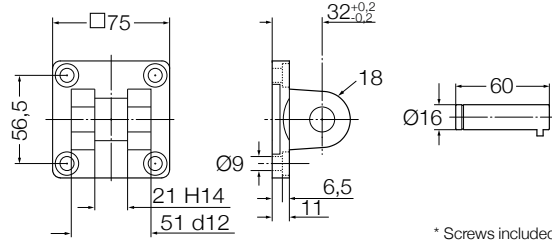

\* Screws included

**Ordering key**  
ZBE-375504-63  
For parallel version only

**Swivel flange with rod end\***

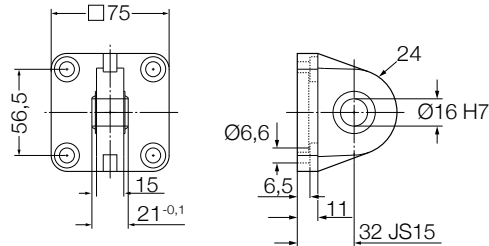

\* Screws included

**Ordering key**  
ZBE-375506-63  
For parallel version only

**Rod clevis**

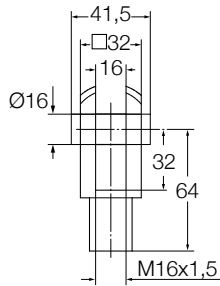

**Ordering key**  
ZBE-375510-63

**Rod end**

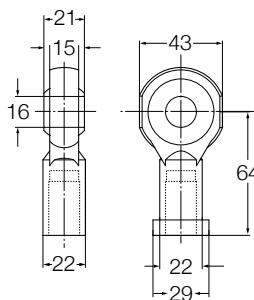

**Ordering key**  
ZBE-375511-63

**Proximity sensor**

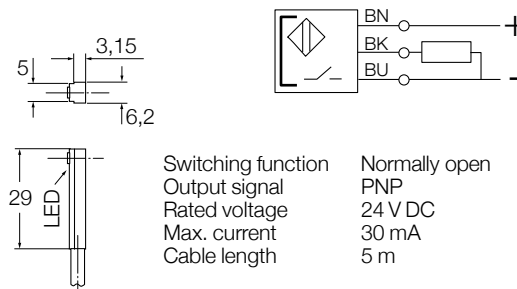

**Ordering key**  
ZSC-375525-NO



[ewellix.com](http://ewellix.com)

© Ewellix

All contents of this publication are the property of Ewellix, and may not be reproduced or given to third parties (even extracts) without permission. Although great care has been taken in the production of this catalog, Ewellix does not take any responsibility for damage or other loss resulting from omissions or typographical errors. The photo may differ slightly in appearance from the actual product. Due to continuous improvements being made in our products, the product's appearance and specifications are subject to change without notice.

**PUB NUM IL-06010/5-EN-March 2023**

Certain image(s) used under license from Shutterstock.com.